

ÖLEVIA

User's Manual

LCD HDTV

ÖLEVIA 540

ÖLEVIA

Syntax-Brilliant Corporation
20480 East Business Parkway
City of Industry, California 91789 USA
1-866-9-OLEVIA



Table of Contents

Important Information	1
Important Safety Precautions	2
FCC Statement	5
Introducing the Syntax-Brilliant OLEVIA TV	6
Accessories	8
TV Installation And Connection Guide	
Identifying Front Controls and Rear Panels	10
- Descriptions of Connector Types	12
- Connecting the Power Cord	13
Installation	14
- Connecting to an Antenna or Video Equipment with Antenna outlet	15
- Connecting to a VCR	16
- Connecting to a DVD Player with A/V or S Video Cables	17
- Connecting to a DVD Player with Component Cables	18
- Connecting to a Satellite Receiver or Cable Box with A/V Cables	19
- Connecting to a Satellite Receiver or Cable Box with Component Connectors	20
- Connecting to a PC with VGA, and a DVD Player or HD-Receiver with DVI/HDCP Cables	21
- Connecting to an Audio Receiver/Home Theater System	22
- Audio Output	23
Remote Control Guide	
- Regular Buttons	24
- Hotkeys Tutorial	25
- Battery Installation	26
Adjusting the On Screen Display (OSD)	
Introduction	27
Operating in the OSD	27
VIDEO Adjusting TV Picture Settings	28
- Adjusting Video or Picture Quality	28
- Video Settings	28
- Advance Picture Adjust	29
- Adjusting Settings	30
- Auto Setting : Return to Default Factory Settings	30
AUDIO Adjusting Sound Quality	31
- Audio Settings	31
- Adjusting Audio Settings	32
- MTS System for Stereo TV	34
MISCELLANEOUS Adjusting Personal TV Settings	35
- Description of Settings	35
- Setting the Channels	36
- Setting Favorites Channels	36
- Editing Channels	37
- Personal Channel Preferences : Channel Naming	38
- Setting up the TV Timer	39
- Watching with Closed Caption	40
- TV OSD Languages	41
- Using the Parental Control Feature	41
- Parental Control	42
- Activating the Parental Control Feature	43
- Blocking Unrated Channels	44
- Setting up Parental Control Password	45
- Factory Default Option	46
SCREEN Adjusting Screen Modes	47
- Changing the Screen Mode	47
- Changing the View Mode	48
- Picture in Picture (PIP)	48
- PIP Mode	50
- Split Screen	51
- Split Screen Mode	52
DTV Adjusting DTV Settings	
- Introduction to DTV	53
- General Options	55
- Caption Options	61
- Parental Options	64
Operating on the Remote Control	67
Wall Mount Kit	71
Specifications	73
Timing Mode for VGA and DVI	75
Pixels Policy	77
Glossary	78

Important Information



Caution
Risk of electronic shock
Do not open



To reduce the risk of electronic shock, do not remove cover (or back).
No user-serviceable parts inside.
Refer service to qualified Repair Technician or Repair Center.



Read the following context indicated by the following symbol to the left. It indicates important literature in operating the product.



Read the following context indicated by the following symbol to the left. It indicates a potential high voltage hazard that may compromise your safety.



Caution

Take caution when moving the product on a cart. Quick stops, excessive force, and uneven surfaces may cause the display unit and cart combination to overturn.

Caution

To prevent electric shock, match wide blade of plug to wide slot, fully insert.

Caution

This product satisfies FCC regulations when shielded cables and connectors are used to connect the unit to other equipment. Prevent electromagnetic interference from electrical appliances such as radios and televisions. Please use shielded cables and connectors for connections.

Warning

FCC Regulations state that any unauthorized changes or modifications to this equipment not expressly approved by the manufacturer could void the user's authority to operate this equipment.

Important Safety Precautions

Cleaning

Remember to unplug the AC cord from the AC outlet before cleaning the display unit. And do not use liquid cleaners or aerosol cleaners to clean the display.

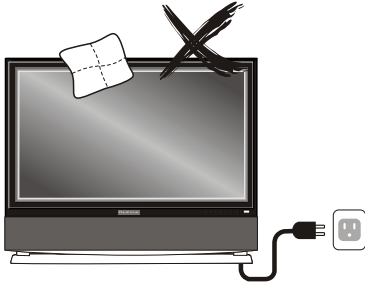

Stand

Do not place the display unit on an unstable place. The TV may fall resulting in serious personal injuries to nearby people as well as damage to the display unit.



Ventilation

Do not cover or block these vents and openings located on the top and back of the display. Inadequate ventilation may cause overheating and shorten the lifespan of the display. Do not place in an enclosed area such as a built-in shelf, unless proper ventilation is provided or the manufacturer's instructions are followed. Keep the distance of 10cm minimum between the display unit and wall. Never install the display unit as indicated in the picture below.

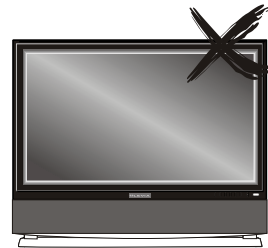

Air circulation is blocked

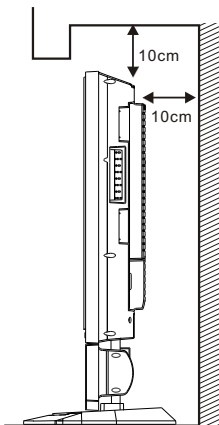

Air circulation is blocked

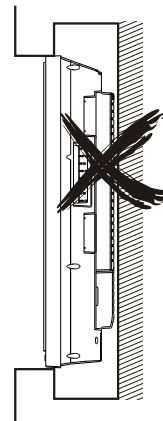

Never insert objects or spill liquid into the display unit

Never insert any object into the display unit through openings or spill liquid on the display unit. High voltage flows in the display unit, and inserting an object can cause electric shock and/or short internal parts.



Keep away from water and moisture

Do not place the display in areas where moisture is present or where the unit may get wet such as bathrooms, kitchen, pool area or in a wet basement.

Keep away from heat sources

Keep the display unit away from heat sources such as radiators, heaters, stoves and other heat-generating products.

The liquid crystal panel used in this product is made of glass

Do not hit the panel. Be careful to prevent from getting hurt by broken glass pieces in case the panel breaks.

Follow operating instructions

All operating instructions must be followed.

Servicing

Do not attempt to service the display unit yourself. Removing covers expose you to high voltage and other dangerous conditions. Request a qualified service technician to perform the service.

Precautions when transporting the display

Carrying the display requires two or more people.

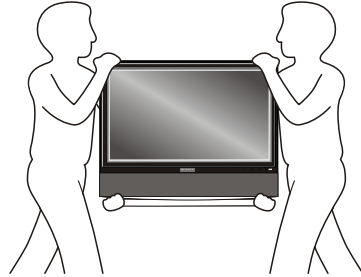

Attachments

Do not use attachments not recommended by the manufacturer. Use of inadequate attachments may result in accidents to nearby people or to the unit.

Power source

This product must operate on a power source specified on the specification label. If you are not sure of the type of power supply used in your home, consult your dealer or local power company. For units designed to operate on batteries or another power source, refer to the operating instructions.

AC cord protection

The AC cords must be routed properly to prevent people from stepping on them or objects from resting on them. Check the cords at the plugs and product.

Wall mounting

Be sure to install the display unit according to the method recommended by the manufacturer. Use only the mounting hardware recommended by the manufacturer.

Overloading

Do not overload AC outlets or extension cords. It may result in electric shock or start a fire.

Replacement parts

In case the display unit needs replacement parts, make sure that the service technician uses replacement parts specified by the manufacturer, or those with the same characteristics and performance as the original parts. Use of unauthorized parts can result in fire, electric shock and/or other danger.

Safety checks

Upon completion of service or maintenance, request the service technician to perform safety checks to ensure that the display unit is in proper operating condition.

Repair

When the display unit displays an abnormal condition, any noticeable abnormality in the display unit indicates that the display unit needs servicing. If any of the following conditions occurs, unplug the AC cord from the AC outlet, and request a qualified service person to perform repairs.

- 1.**A liquid was spilled on the display unit or objects have fallen into the display unit.
- 2.**The display unit has been exposed to rain or water.
- 3.**The display unit has been dropped or damaged.

Environment

The display unit only operates within the temperature 0°C to 40°C. Operation outside of the recommended may cause damage to your product.

FCC Statement

FCC notice

This equipment has been tested and found to comply with the limits for a Class B digital device, pursuant to part 15 of the FCC Rules. These limits are designed to provide reasonable protection against harmful interference in a residential installation. This equipment generates, uses and can radiate radio frequency energy and, if not installed and used in accordance with the instructions, may cause harmful interference to radio communications. However, there is no guarantee that interference will not occur in a particular installation. If this equipment does cause harmful interference to radio or television reception, which can be determined by turning the equipment off and on, the user is encouraged to try to correct the interference by one or more of the following measures:

- 1.Reorient or relocate the receiving antenna.
- 2.Increase the separation between the equipment and receiver.
- 3.Connect the equipment into an outlet on a circuit different from that to which the receiver is connected.
- 4.Consult the dealer or an experienced radio/TV technician for help.

Modifications not expressly approved by the manufacturer could void the user's authority to operated the equipment under FCC rules. This device complies with part 15 of the FCC Rules. Operation is subject to the following two conditions:

- 1.This device may not cause harmful interference.
- 2.This device must accept any interference received, including interference that may cause undesired operation.

For Canadian model

This Class B digital apparatus complies with Canadian ICES-003.

Approval



Introducing the Syntax-Brilliant™ OLEVIA™ TV

Welcome!

Thank you for purchasing a Syntax-Brilliant™ OLEVIA™ LCD HDTV. This manual is to be used with the following model:

Olevia 540

This manual is designed to help you through setting up and operating your LCD HDTV as quickly as possible. The model and serial numbers are on the back cover of your TV. Write these numbers in the space provided in this manual for your records. Please read all the safety and operating instructions carefully, and keep this manual for future reference.

Owner's Record

The model and serial numbers are located at the rear of the display unit, or on the side of the media receiver unit on the cartons (white label). Record these numbers in the spaces provided below. Refer to them whenever you call upon your Syntax-Brilliant™ Groups Corporation or local dealer regarding this product.

Model No. _____

Serial No. _____

Package Contents

- Syntax-Brilliant™ OLEVIA™ display unit
- Remote Control
- 1 AC power cord
- Quick Start Guide
- Warranty Card

These items are all you need to set up and operate the TV in its basic configuration.

Note: Most components (VCRs, DVD players, etc.) come with the necessary cables to connect them. If you want to set up a complex system, you may need to buy extra cables, connectors, etc. Be sure to have these on hand before you start to connect your system.

Syntax-Brilliant™ OLEVIA™ LCD HDTV includes many features you will enjoy throughout the usage of your TV. These highlighted features include:

Fully Integrated HDTV (High Definition TV):

HDTV delivers a stunning picture far beyond the quality of standard televisions. These programs offer crystal clear video with amazing detail played with enhanced audio quality of digital television programs. You can enjoy better sound and picture in movies, prime time TV shows, and other HD broadcasts in dynamic television settings through cable, satellite or even free broadcasts over the air.



IDEA (Innovative Digitally Enhanced Architecture):

Syntax-Brilliant's proprietary digital video processing technology, a highly integrated System-On-a-Chip, delivers an exceptional solution to digital display complexities commonly associated with color, contrast, sharpness, motion, noise and audio lip-sync. It's a suite of built-in and user-selectable video/audio features that deliver precise colors, sharp resolutions and audio synchronization through its advanced Digital Sound Processor (DSP) technology.



IDEA includes a variety of preprogrammed and user-selectable image enhancements including:

- Dynamic Brightness and Contrast
- Pure Edge Enhancement
- Dynamic Noise Reduction
- Black Level Extender
- White Peak Limiter
- Advanced Digital Sound Processor
- Clarity of audio synchronization of built in sound technology

Super IPS Technology (Super In-Plane Switching Technology):

Superior panel technology provides the best image performance for LCD HDTVs with higher color saturation, widest viewing angles, sharpest images and best response times while reducing to the minimal amount, color shift and distortion at any angle.



ATSC Digital Tuning System:

Enables the television set to receive digital ATSC signals, as well as digital terrestrial broadcasts for a wide variety of channels and shows.



HDMI (High Digital Multimedia Interface):

The next generation of DVI, HDMI provides the best interface between a DVD player and compatible products such as digital set top box for uncompressed digital audio/video connections. When matched with a Syntax-Brilliant™ OLEVIA™ HDTV, multi-channel digital audio signals, uncompressed DVI digital video and intercommunication between high multimedia interfaces are combined through a single interconnecting cable.



Accessories

Supplied Accessories

Remote control & batteries (AAA x 2)



User Manual (CD-ROM) x 1



QSG x 1



Power cord x 1



Optional Accessories

AV cable with RCA connector



S-video cable



HDMI cable



Audio cable with RCA connector



Component cable with RCA connector



VGA cable (D-Sub 15 male) x 1



Use the proper cable for the device.

Audio Cable with Stereo Mini Jack



(Stereo mini jack cable)



(Stereo mini jack to RCA cable)

Wall Mount Set

Model# WM-30D

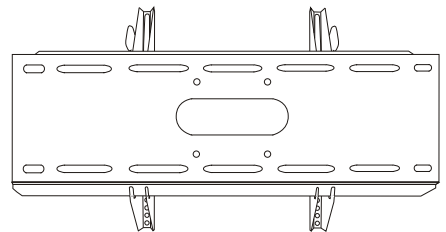

1. Before using the wall mount, please read manual in Page 71 and following assembly guide.
2. For safety purpose, please purchase wall mount which can bear the LCD HDTV weight.
3. Following installation instruction is only for your reference.
4. Please consult authorized service personnel for the installation of wall mount.

TV Installation and Connection Guide

Identifying Front and Rear Panels

Front Panel



POWER Turns display on/off

MENU Displays the On Screen Display(OSD) menu. In OSD menu, press it to return to the previous screen or to exit.

CH▲ / CH▼ Adjusts Channel. In the OSD menu, both keys are used to navigate within menu.

VOL+/VOL- Adjusts Volume. In the OSD menu, both keys are used to navigate within menu. Vol+ is used to select the highlighted option.

SOURCE Press to switch the input sources.

IR SENSOR Contains Infra-red light for digital data transmission by the remote control. Please point remote control at IR Sensor for function.

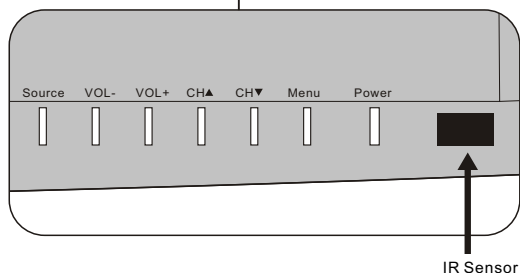

Identifying Front and Rear Panels

Rear Panel

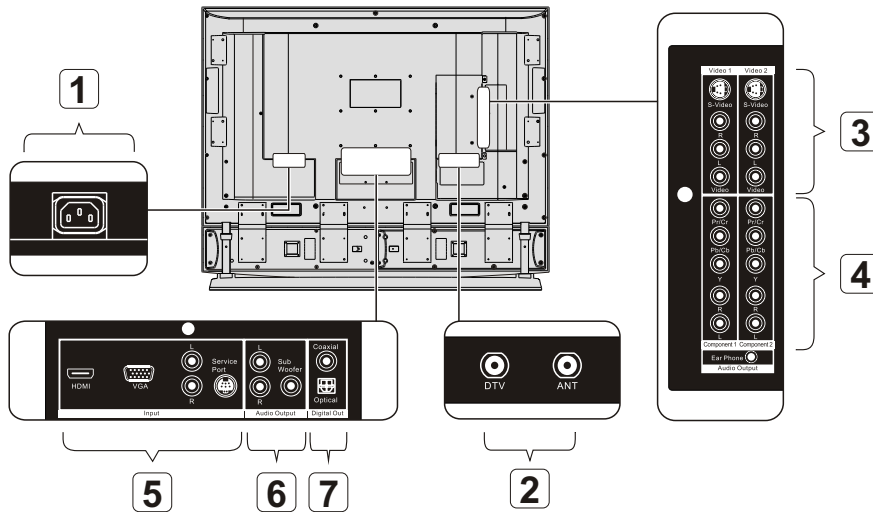

1 AC IN power cord connects here.

2 Antenna (ANT) Antenna receives signals from VHF/ UHF antennas or a cable system.

DTV Digital Television Input

The DTV input receives digital broadcasts programs on VHF/UHF TV signals from a built in ATSC digital receiver.

3 Video 1,2 These inputs can be used for the connection of a VCR, Super VHS (S-VHS) VCR, DVD player, or other video devices to the TV. There is a Video and an S-Video input for Video 1 and video 2. When both inputs are used simultaneously on Video 1, only the S-Video input will be recognized. Same behavior for Video 2. The display will automatically detect the input being used.

NOTE: The S-Video input has a better quality of picture than a composite Video signal.

4 Component 1, 2 These inputs can be used for the connection of A/V equipment with component video outputs, such as a DVD player, Digital Satellite Receiver, or compatible Video Game System.

5 HDMI and VGA Port This display includes a HDMI input that receives analog or digital video signals through the interface for the display of high quality digital video signals. The HDMI port is HDCP (High Bandwidth Digital Content Protection) compliant and is fully compatible with video equipment that features the HDCP function. The VGA input can be used for analog RGB signals from a HD Receiver or personal computer. Resolutions supported are VGA, SVGA, XGA and WXGA.

Service Port is reserved for manufacturer use. Incorrect use may damage the Display.

Audio In The Audio Input receives an A/V receiver's connected audio signals to the TV.

6 Audio Out The Analog Audio Output sends the TV's connected analog audio signals to an A/V receiver or other equipment. Display features a R/L stereo and Subwoofer output.

7 Digital Out The Digital Audio Output sends the TV's connected digital audio signals to an AV receiver or other equipment, such as the amplifier. Display features a Coaxial or Optical output.

Descriptions of Connector Types

You may find it necessary to use some of the following connector types during setup.

75-ohm coaxial cable Used for TV cable connection .



S-Video Cable High quality video cable for enhanced picture quality.



Audio/Video Cable

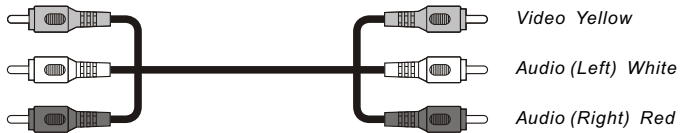

Some DVD players are equipped with the following three video connectors:

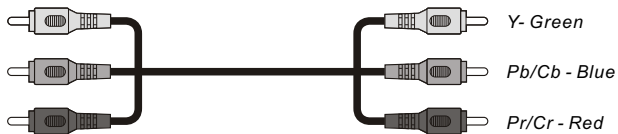

Connecting the Power Cord

Complete other connections prior to connecting the power cord:

1. Connect the power cord to the AC IN connector of the TV.

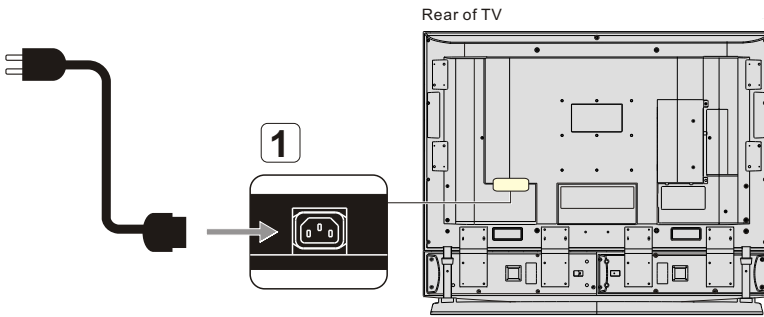

2. Connect the other end of the power cord to the wall outlet.



Installation

In the following pages, you will find directions on how to install your tv and choice of video equipment.

- **Connecting to an Antenna or Video Equipment with Antenna outlet**
- **Connecting to a VCR**
- **Connecting to an Audio Receiver/Home Theater System**
- **Connecting to a DVD Player with A/V or S Video Cables**
- **Connecting to a DVD Player with Component Cables**
- **Connecting to a Satellite Receiver or Cable Box with A/V Cables**
- **Connecting to a Satellite Receiver or Cable Box with Component Connectors**
- **Connecting to a PC with VGA, and a DVD Player with HDMI/HDCP Cables**
- **Audio Output**

Connecting to an Antenna or Video Equipment with Antenna outlet (for TV and DTV source)

⚠️ Disconnect all power sources before making any connection.

1. Connect a 75-ohm coaxial cable (or choice of Antenna Cable) onto the splitter's IN jack.
2. Using two of the 75-ohm coaxial cables, connect two of the splitter's OUT jacks to the TV's ANT and DTV jacks (RF Terminal).

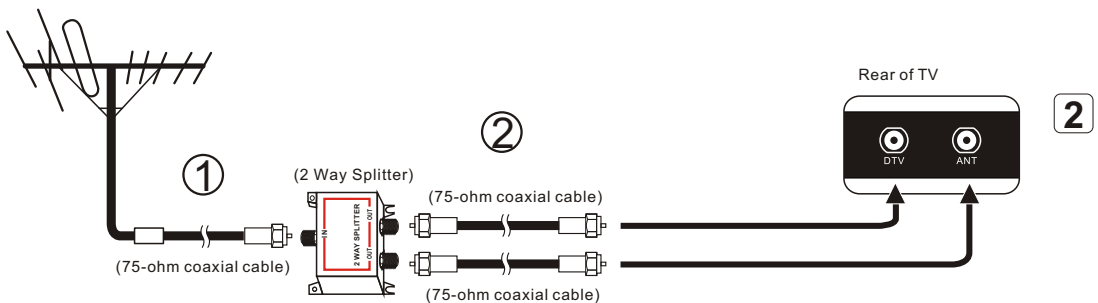

If connecting to Video Equipment with Antenna outlet

1. Connect a 75-ohm coaxial cable (or choice of Antenna Cable) onto the Video Equipment's IN jack.
2. Using two of the 75-ohm coaxial cables, connect two of the Video Equipment's OUT jacks to the TV's ANT and DTV jacks (RF Terminal).

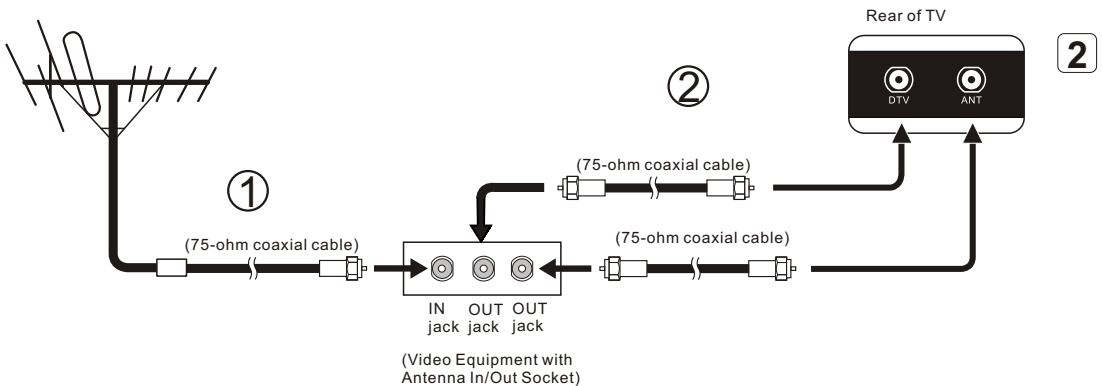

Connecting to a VCR

⚠ Disconnect all power sources before making any connections.

Use this method of connection if you subscribe to a cable TV system that does not require a cable box.

1. Using A/V cable and S-Video cables, connect the VCR's Audio and S Video OUT jacks to the TV's Audio and S-Video In jacks.

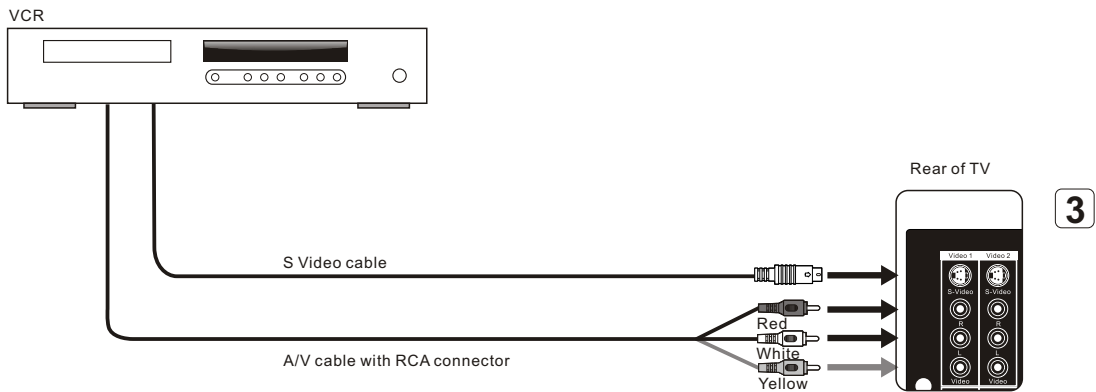

Connecting both Video IN and S-Video IN

Note: When you connect video equipment to both the same Video and S-Video input jacks, display will automatically select S-Video first. To view Video signal, please disconnect the S-Video jack or turn off the S-Video signal on the video equipment.

S-Video is strongly recommended for use if your VCR or video equipment has it. S-Video input has a better quality of picture than a composite Video signal.

Connecting to a DVD Player with A/V or S Video Cables

⚠ Disconnect all power sources before making any connections.

Use this method of connection if your DVD player does not have component (Y, Pb, Pr) jacks.

Note: If your DVD player has component video output connectors, for best picture quality, use the connection described for *Connecting to a DVD Player with Component Connectors.* (See page.18)

1. Using an A/V cable, connect the DVD player's Audio OUT jacks to the TV's Audio IN jacks.
2. Using an SVideo Cable, connect the DVD player's S Video OUT jack to the TV's S Video IN jack.

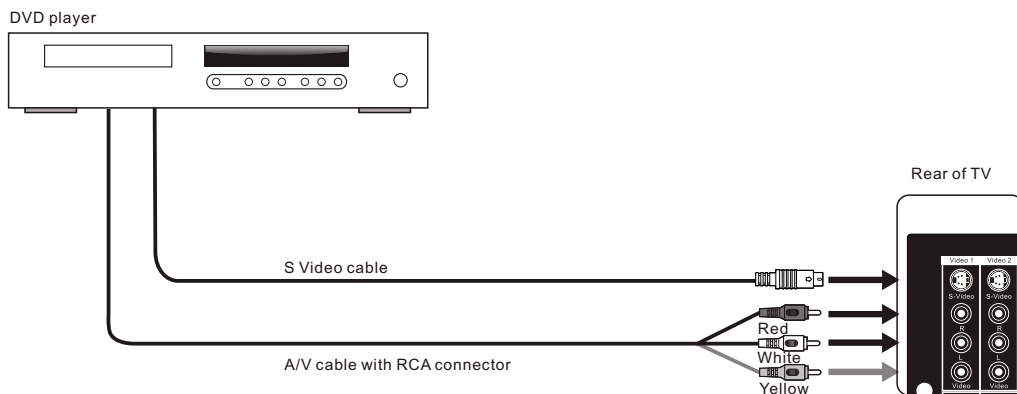

Note: When you connect video equipment to both the same Video and S-Video input jacks, the display will automatically select S-Video first. To view Video signal, please disconnect the S-Video jack or turn off the Video signal on the video equipment.

S-Video is strongly recommended for use if your VCR or video equipment has the option. S-Video input has better quality of picture than a composite Video signal.

Connecting to a DVD Player with Component Cables

⚠ Disconnect all power sources before making any connections.

Use this method of connection if your DVD Player has component (Y, Pb, Pr) jacks.

1. Using a component video cable, connect the DVD Player's Y, Pb and Pr jacks to the Y, Pb and Pr jacks on the TV.

Colors on Component Video connectors:

Y: Green

Pb (also identified as Cb, CB or B-Y): Blue

Pr (also identified as Cr, CR or R-Y): Red

Note: The Y, Pb and Pr jacks on your DVD player are sometimes labeled as Y, Cb and Cr, or B-Y and R-Y. If so, connect the cables to the matching colors.

2. Using an Audio cable, connect the DVD player's Audio OUT jacks to the TV's Audio in jacks.

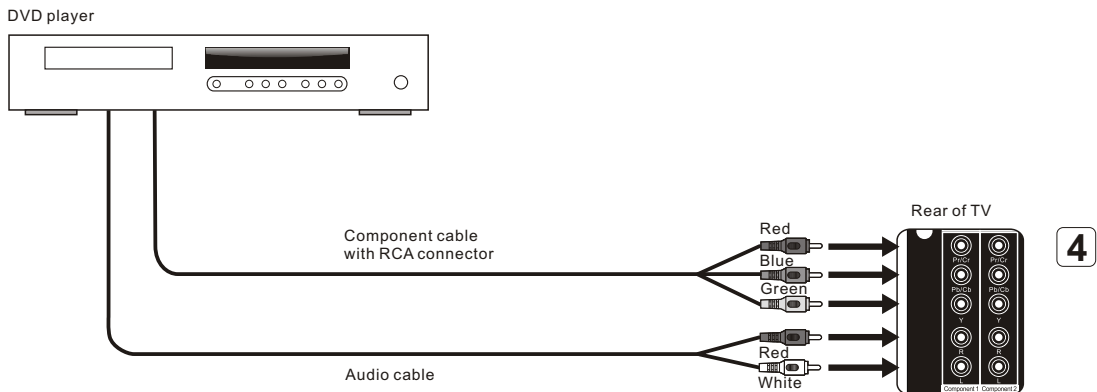

Note: The Y, Pb and Pr jacks do not provide audio, so audio cables must be connected to provide sound.

Note: The YPbPr connection provides the best quality of video signal compared to AV (Composite) and S-Video connection.

Connecting to a Satellite Receiver or Cable Box with A/V Connectors

⚠ Disconnect all power sources before making any connections.

1. Connect a 75-ohm coaxial cable from your Cable TV to the Satellite Receiver's or Cable Box's Ant (Antenna) jack.
2. Using Audio and S Video cables, connect the satellite receiver's Audio and S Video OUT jacks to the TV Audio and S Video IN jacks.

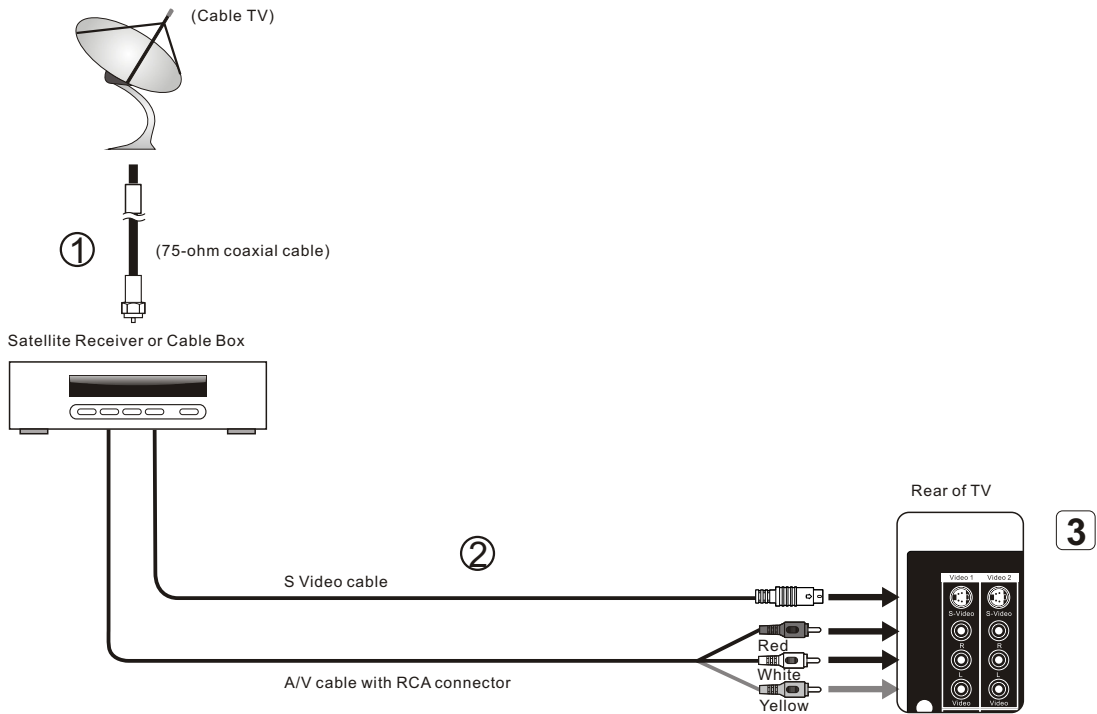

Note: When you connect video equipment to both the same Video and S Video input jacks, display will automatically select S Video first. To view S Video signal, please disconnect Video jack or turn off the Video signal on the video equipment.

S-Video is strongly recommended for use if your VCR or video equipment has it because S-Video input has better quality of picture than a composite Video signal.

Connecting to a Satellite Receiver or Cable Box with Component Connectors

⚠ Disconnect all power sources before making any connections.

Use this method of connection if your Satellite Receiver or Cable Box has component (Y, Pb, Pr) jacks.

1. Using a component video cable, connect the Satellite Receiver or Cable Boxes' Y, Pb and Pr jacks to the Y, Pb and Pr jacks on the TV.

Colors on Component Video connectors:

Y: Green

Pb (also identified as Cb, CB or B-Y): Blue

Pr (also identified as Cr, CR or R-Y): Red

Note: The Y, Pb and Pr jacks on your Satellite Receiver or Cable Box are sometimes labelled as Y, Cb and Cr, or B-Y and R-Y. If so, connect the cables to the matching colors.

2. Using an Audio cable, connect the Satellite Receiver or Cable Boxes' Audio OUT jacks to the TV's Audio in jacks.

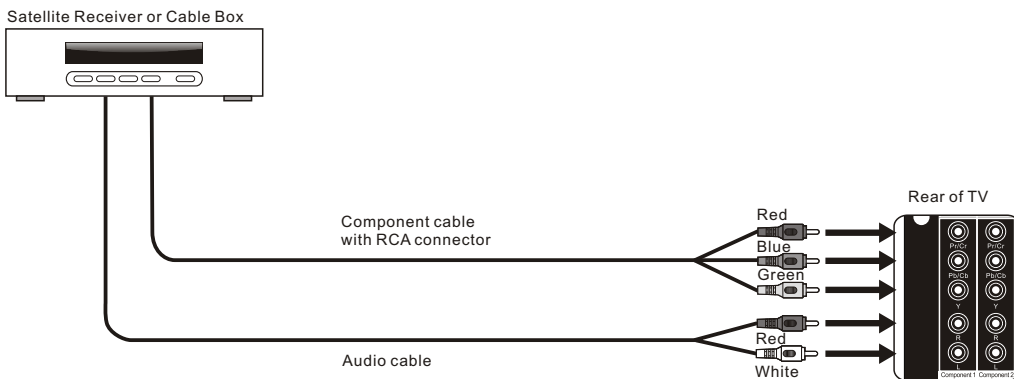

Note: The Y, Pb and Pr jacks do not provide audio, so audio cables must be connected to provide sound.

Note: The YPbPr connection provides the best quality of video signal compared to AV (composite) and S-Video connection.

Connecting to a PC with VGA Connector

⚠ Disconnect all power sources before making any connections.

1. Using a D-Sub 15 pin cable, connect the VGA output terminal of the PC to the TV's VGA signal input terminal.
2. You may need to use a Stereo mini jack to RCA L/R connectors to receive audio.

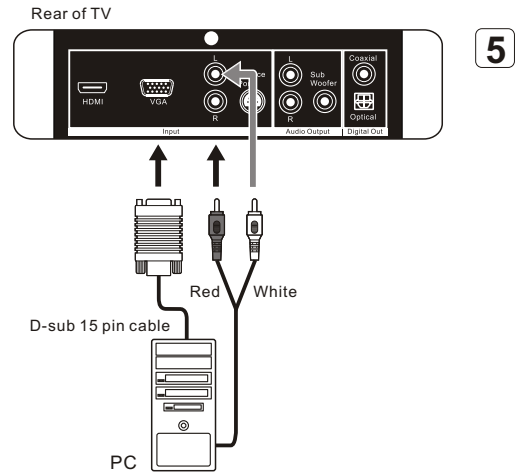

Connecting to a DVD Player or HD-Receiver with a HDMI Cable

⚠ Disconnect all power sources before making any connections.

1. Using a HDMI cable, connect the DVD's HDMI output terminal to the TV's HDMI-HDCP input terminal.

Note: HDCP is a copy protected digital connection that receives analog or digital video signals from equipment with a HDMI output that features the HDCP function. HDMI allows the transfer of digital uncompressed data to the TV. This connection is superior when compared to the Component, S Video or AV (composite) connections.

Note: HDMI signal is purely digital and provides a crystal clear technology better than component, S-Video or Video connections. It is strongly recommended to use this connection if you have this function on your equipment.

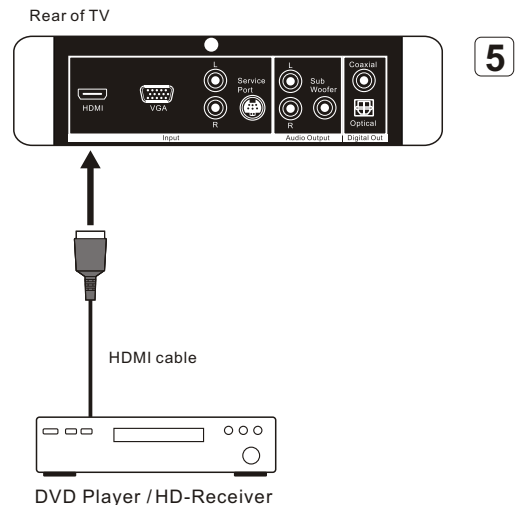

Connecting to an Audio Receiver / Home Theater System

⚠️ Disconnect all power sources before making any connections.

(For Analog Audio Source)

- Using the R/L audio cable, connect the TV's audio OUT jack to the audio receiver's audio IN or AUX IN jacks.

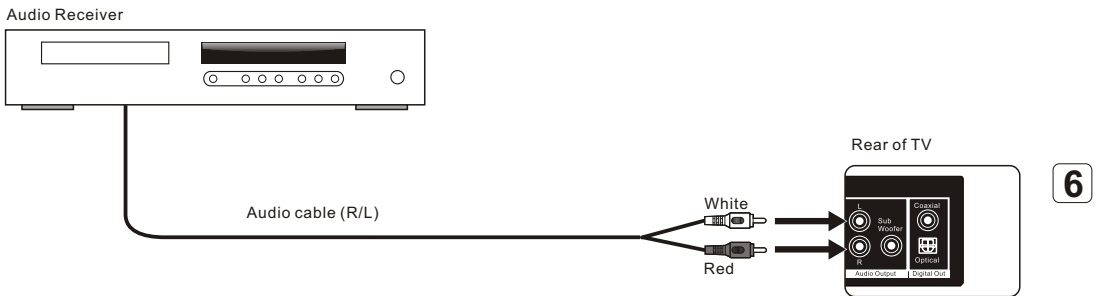

(For Digital Audio Source)

- Using the Coaxial or Optical audio cable, connect the TV's digital OUT jack to the audio receiver's Coaxial or Optical IN jack.

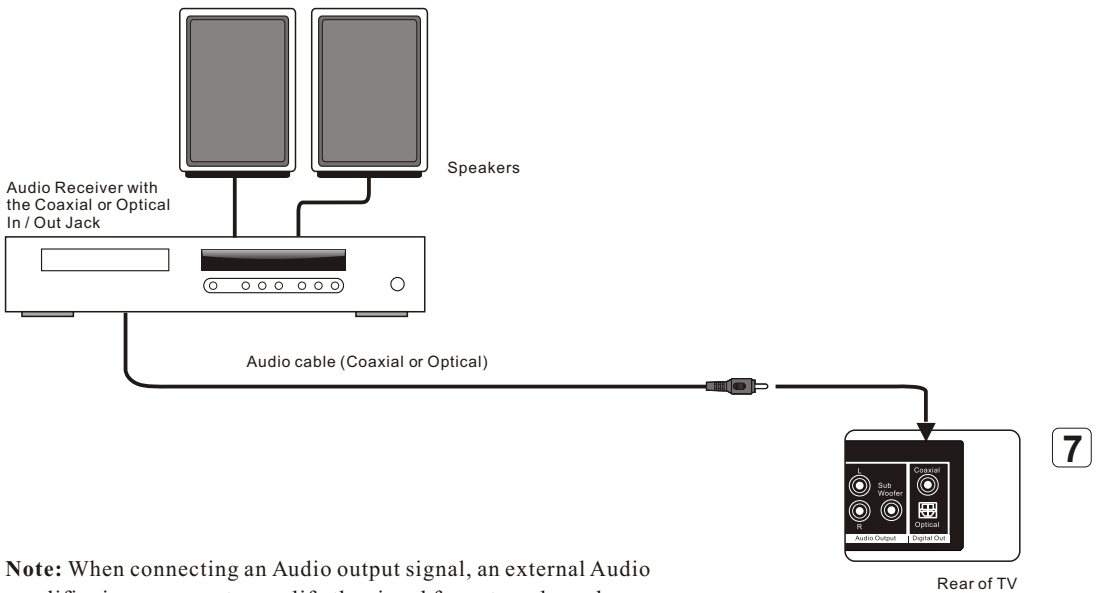

Note: When connecting an Audio output signal, an external Audio amplifier is necessary to amplify the signal for external speakers.

Note: If you connect a Home Theater Sound System, please disable the TV's speakers in the OSD by selecting off in audio section. Volume adjustment must be made on the Home Theater Receiver. By not disabling the TV's speakers it may cause the speakers or the TV itself damage.

Audio Output

⚠ Disconnect all power sources before making any connections.

See setup instructions for: Connecting to an Audio Receiver on page 22.

Note: Speakers must be amplified using an audio receiver such as a Home Theater System to amplify the audio from the TV.

Speaker Outputs

Subwoofer Output

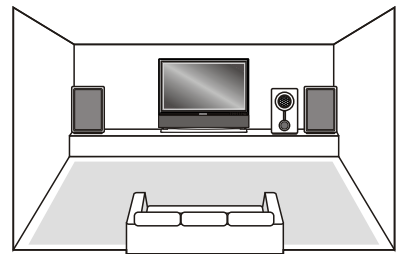
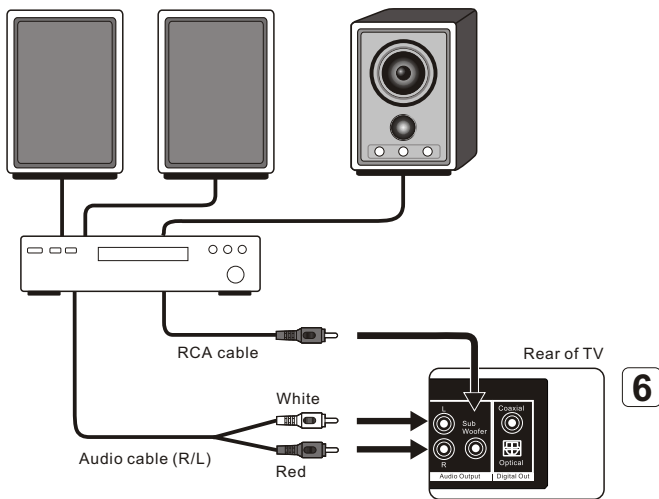

Headphone Set

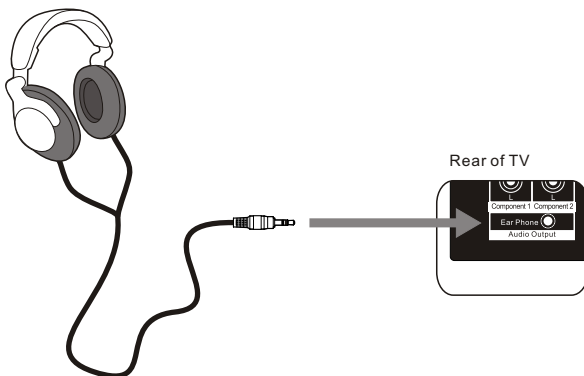

Note: When headphone is plugged in the speaker, it will turn into mute mode.

Remote Control Guide

Remote Function Keys & Description

Regular Buttons

- 1 MUTE** Press to mute the sound.
- 2 NUMBER BUTTONS** Press the number buttons to select channels on the display.
- 3 CH RTN (Channel return)** Press to return the previous-channel.
- 4 MTS** Press to switch the TV Audio System between SAP, Mono or Stereo mode.
- 5 VOL+ / VOL -** Press to adjust the volume.
- 6 FAVORITE** Press to select favorite channels. Can be preset in OSD Menu.
- 7 DISPLAY** Press to display the information of current channel number and time.
- 8 POWER** Press to turn display on/off.
- 9 -** Press to select sub-channel.
- 10 MENU** Press to activate or close the On Screen Display menu. In OSD Menu, acts as a cancel button while navigating through the OSD.
- 11 CH + / CH-** Press to adjust channel up and channel down.
- 12 ENTER** Press to enter the channel number, highlighted menu or submenu item.
- 13 SOURCE** Press to show the source input from TV, Video 1, Video 2, S-Video 1, S-Video 2, Component 1, Component 2, HDMI, VGA, and DTV.
- 14 EPG** (Optional function currently unavailable)
- 15 Hotkeys** Press to directly access certain Shortcut TV functions.

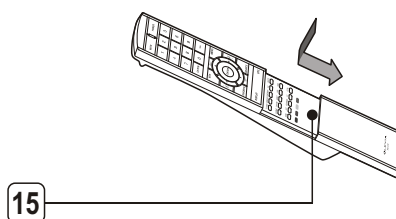
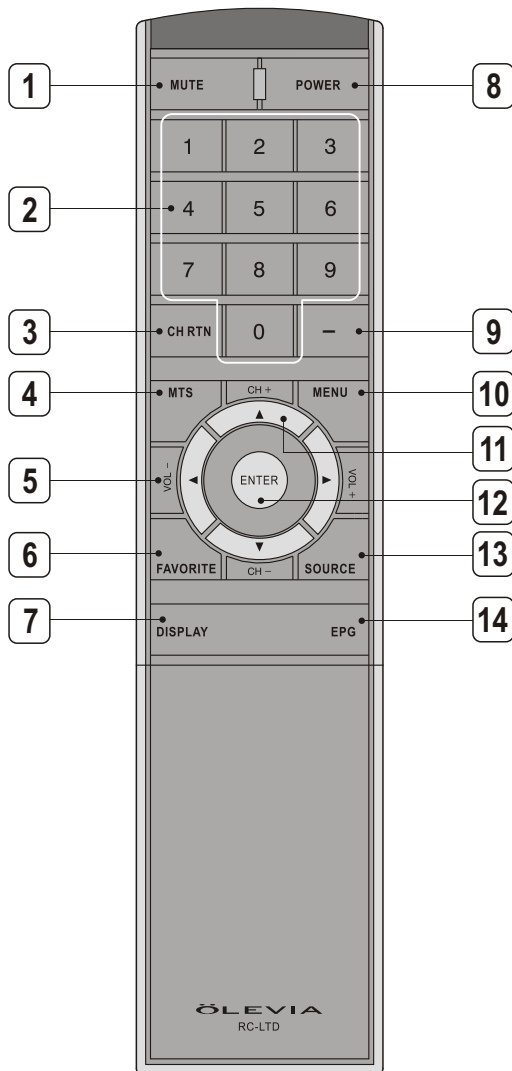

Hot Keys Tutorial

The remote control contains 15 additional "Hotkeys" that represent direct access to a certain function on your TV. Hotkeys enable you to directly change the setting to your preference without having to navigate through the OSD (On Screen Display) Menu.

How to Use Your Hot Keys

HOT KEY FUNCTION

TV/VIDEO Press to switch between TV and source as Video 1 and Video 2 Mode.

HDMI/VGA Press to switch to HDMI or VGA Mode.

COMPONENT Press to switch between Component 1 and Component 2.

C.R. (Optional function currently unavailable)

FREEZE Press to freeze the picture. Press again to unfreeze the picture.

V.FORMAT (Optional function currently unavailable)

CAPTURE (Optional function currently unavailable)

ASPECT Press to change the aspect ratio (Full, 4:3, 16:9, Panoramic) and letterbox modes.

VIEW Press to select and program PIP and Split Screen viewing options.

SWAP Press to swap the positions of the source when in PIP or Split Screen modes.

ZOOM Press to select zoom function (2X,4X,8X,16X,32X,1/2,1/4,1/8, 1/16,1/32).

EXIT Press to go back to the previous menu.

ADD/ERASE Press to add or erase your favorite channel.

C.C. Press to call up the Closed Caption (CC) and Caption Service (CS) list. You can pre-select one to see Closed Caption.

P.CTRL Press to access Parental Control password and/ or program parental locks.

COLOR BUTTONS (Optional function currently unavailable)

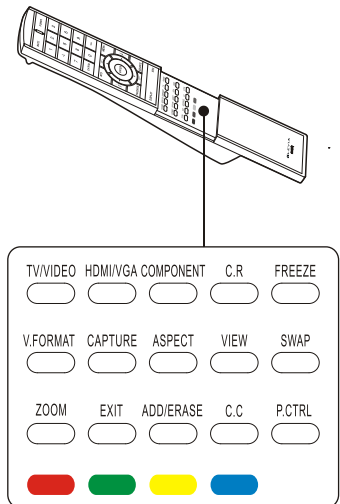

Battery Installation

1. Push the tab and pull it out as illustrated below.
2. Insert two size AAA batteries (supplied) by matching the (+) and (-) on the batteries to the diagram inside the remote control's battery department.
3. Replace the cover back and make sure the cover "snaps" into the remote control.

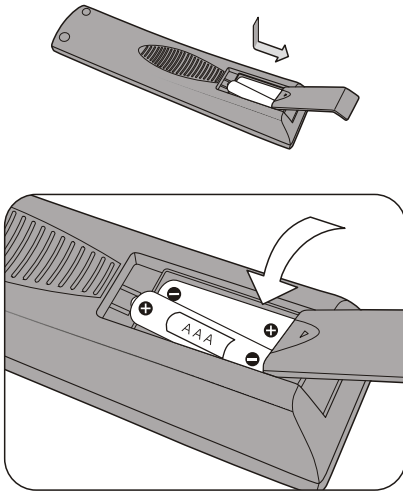

Note:

1. The display unit comes with two new AAA batteries as accessories. However, due to uncontrollable causes, the electricity of the accessorized batteries may be partially or completely drained. We do not warrant the quality of the batteries in any case since many factors are considered. If replacement is needed, please purchase two AAA batteries.
2. Handle remote with care. Avoid dropping it, placing in direct sunlight, near a heater, high areas of humidity or getting it wet. If the remote gets wet, please wipe it dry immediately. In the event of the remote not working properly or is inoperational, a replacement of remote control may be required.
3. If you do not use the remote control for a long period of time, please remove the batteries and store in a cool place to preserve battery life.
4. Do not mix new and used or with different types of batteries for operation.

Adjusting On Screen Displays (OSD)

Introduction

After you have finished connecting your TV, you are now ready to choose and personalize your TV settings in the OSD (On Screen Display) menu.

There are four main sections in the OSD Menu:



Video Audio Miscellaneous Screen DTV

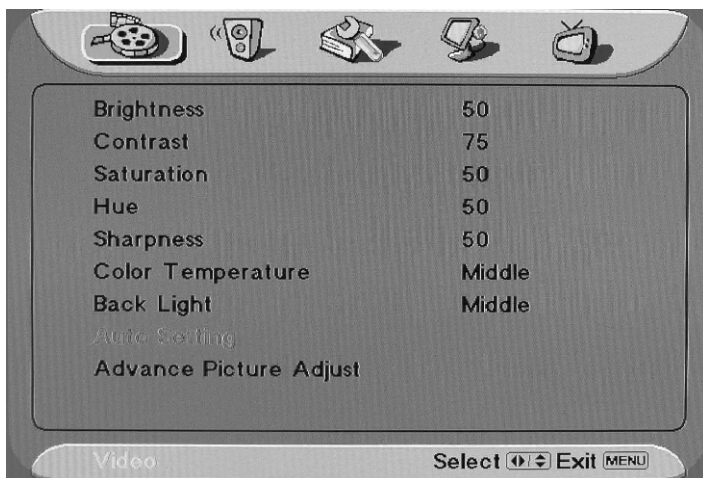

Operating in the OSD

1. Press "Menu" button to enter OSD menu mode.

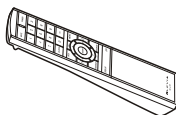

2. To select between main functions, use the keys "VOL - " and " VOL+ "

3. To select the function, press the keys "CH+ " and "CH- "

4. To adjust the value bar, used the keys "VOL - " and " VOL+ "

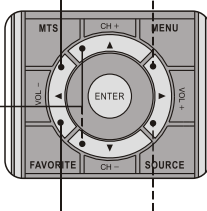

5. After choosing your setting, press "Menu" to exit and back to last picture.



6. To exit the OSD menu, press "Menu" again and again until exit the OSD menu, or without action for 12 seconds of inactivity. This is also adjustable in the OSD.



VIDEO Adjusting TV Picture Settings

Adjusting Video or Picture Quality

In this Setup Index, you can adjust the video and picture settings to suit your personal preferences.



Video Settings

Item	Adjustment	Function
Brightness	0~100	Adjusts picture brightness contrast
Contrast	0~100	Adjusts picture color contrast
Saturation	0~100	Adjusts the color intensity
Hue	0~100	Adjusts the tint or shade of picture
Sharpness	0~100	Adjusts the picture sharpness or softness
Color temp	Cool / Middle / Warm / User	Adjusts image color intensity. Cool: More blue-tinted colors Middle: Standard color temperature Warm: More red-tinted colors User: Allows User to adjust RGB Gain
Red Gain	0~100	Adjusts the color control with red tones
Green Gain	0~100	Adjusts the color controls with green tones
Blue Gain	0~100	Adjusts the color controls with green tones
Backlight	Bright / Middle / Dark	Adjusts the darkness or lightness of the screen
Auto Setting	Enter	Adjusts OSD Settings back to factory default
Advance Picture Adjust	Enter	Adjusts additional specific picture settings (DNR, Black Level Extender, White Peak Limitorator, Flesh Tone, Adaptive Luma Control)

Advance Picture Adjust

To further adjust specific picture settings, enter this function by pressing the ► button.

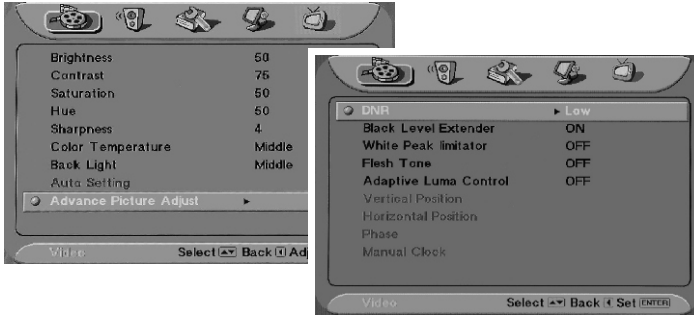

Advance Picture Adjust

Definition of Terms

Item	Status	Description and Function
DNR	Off/Low/Middle/Strong	DNR-Dynamic Noise Reduction. Reduces high frequency noise dynamically. Off- Dynamic Noise Reduction is disabled. Low/Middle/Strong---Set the DNR in low/medium/strong degree.
Black Level Extender	On/Off	Black Level Extender -Extends "grays" to black so a more accurate picture is produced with a wider contrast scale. On-The Black Level Extender is enabled. Off-The Black Level Extender is disabled.
White Peak Limiator	On/Off	White Peak Limiator-Limit the signal amplitude varying degree resulted in brightness over saturation. On-The White Peak Limiator is enabled. Off-The White Peak Limiator is disabled.
Flesh Tone	On/Off	Most LCD HDTV's video processing solutions have a red push to the their color matrix. With the FleshTone Control option, it helps to tone down these strong reds and produce more naturalistic color tones. On-Flesh tone adjustment is enabled. Off-Flesh tone adjustment is disabled.
Adaptive Luma Control	On/Off	Control the luminance adaptively. On-The Adaptive Luma control feature is enabled. Off-The Adaptive Luma control feature is disabled.

Adjusting Settings:

Use the ► and ◀ remote buttons to adjust each Video picture setting, as seen below:

Brightness

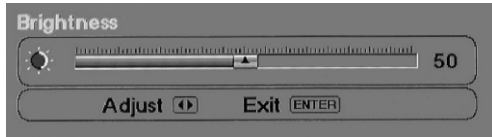

Saturation

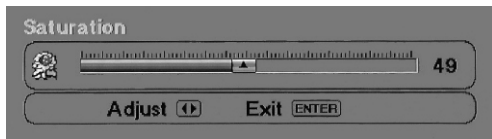

Hue

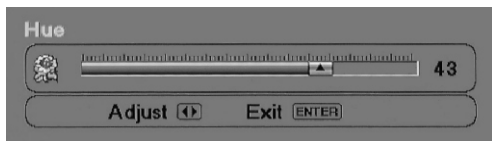

To return to the main menu, press the  Button.

Returning to Default Factory Settings

If, at any time, you wish to go back to original factory setting, you may do so by choosing the Default setting in the OSD Picture and Audio Sections.

Selecting "Default," will reset all OSD settings to the original manufacture settings. The only items which will remain unaffected, are:

- Clock
- Auto Scan Channels
- Edited Channels
- Parental Control Password

Audio Adjusting Sound Quality



Audio setting

Definition of Terms

Item	Adjustment	Function
Treble	-50~50	Adjusts higher pitched sounds
Bass	-50~50	Adjusts lower pitched sounds
Balance	-20~20	Adjusts volume balance in Left and Right
Surround	On / Off	Creates a panoramic stereo audio image by producing deep and rich bass tones and clear treble tones. This enables you to enjoy powerful sound effects like those in a movie theatre
Reverb	Off, Concert, Living Room, Hall, Arena, Church	Adjusts the sound as occurred in an enclosed space of varying spaces
Equalizer	Off, Rock, Pop, Live, Classic, Soft	Adjusts the volume of different bands (ranges of frequencies (HZ)) to control the overall sound
MTS	Mono, Stereo, SAP	Adjusts sound reception of stereo, bilingual and mono programs under the TV Source.
Speakers	On / Off	Turns off the speakers of the TV when using a Receiver or Home Theater System.

Adjusting Settings:

Use the ► and ◀ remote buttons to adjust each Audio sound quality, as seen below:

Treble

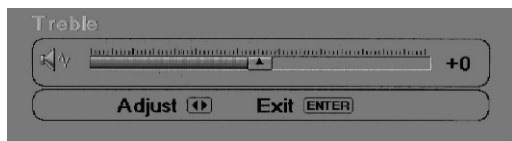

Bass

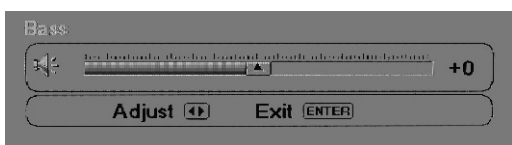

Balance

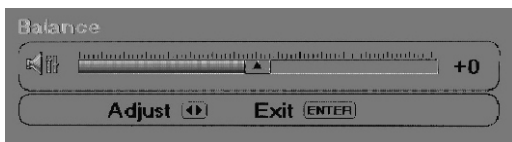

Surround Sound is an available option for creating a panoramic stereo audio image by producing deep and rich bass tones and clear treble tones. This enables you to enjoy powerful sound effects like those in a movie theater.

Speakers

Must turn off speakers of the TV when using a Receiver or Home Theater System.

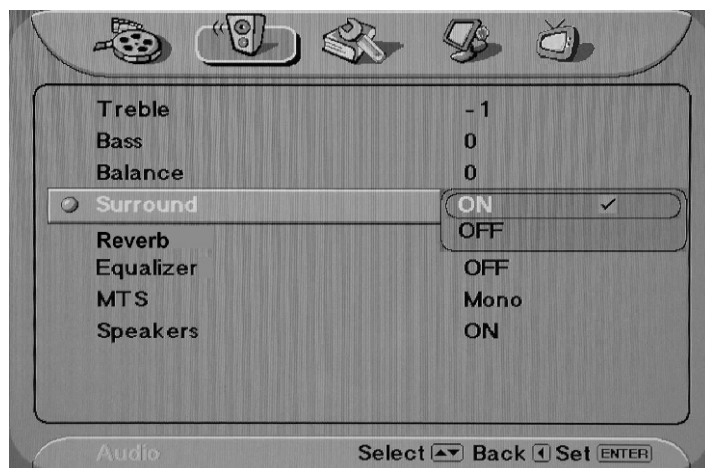

OSD Audio Settings: Reverb**OSD Audio Settings: Equalizer**

MTS System for Stereo TV

You can enjoy stereo, bilingual and mono programs.



Additionally, you can press the hotkey "MTS" until the desired sound indication appears. Each time you press the button, the sound indication changes as follows:

Mono, Sap, Stereo

Definition of Terms

Sound Effect	Description
Stereo	Select for stereo reception when viewing a program broadcast in stereo
SAP	Select to automatically switch the TV to Secondary Analog Program when a signal is received. (If no SAP signal is present, the TV remains in Stereo Mode)
Mono	Select for mono reception. (Use to reduce noise during weak stereo broadcasts)

MISCELLANEOUS Adjusting Personal TV Settings

In this Section, you can adjust additional TV settings to your personal preference, including channel setup, choosing tuner modes, setting up timer, closed caption services, parental controls, and viewing the OSD in your preferred language.



Description of Settings

Item	Adjustment	Function
Channel Setup		Setting up Channel functions
Channel Favorite		Stores the favorite channels
Channel Skip	24 favorite channels setting	Sets up available channels. Add : To add available channel. Skip : To cancel available channel
Channel Name		Stores channel names
Channel Lock		Lock : To lock available channel.
Color System	Auto / PAL / PAL-M / PAL-N / NTSC358 / NTSC443 / SECAM	Selects the suitable TV System where you live.
Tuner Mode	Air / Cable	
Auto Search		Selects to auto scan the available channels of the TV or CATV.
Timer	Time, Start/Stop Time, Channel, Activate option, Display option	Set Alarm with channel preference
Closed Caption	C1, C2, C3, C4, T1, T2, T3, T4	Switches different types of caption or cancel caption functions.
Parental	MPAA G/PG/PG-13/R/NC-17/X TV Rating TV-Y/ TV-Y7/ TV-Y7-FV TV-G/ TV-PG(V,S,L,D)/ TV-14(V,S,L,D) / TV-MA(V,S,L) MPAA Unrated TV None Rating Change Password	Adjusts MPAA and TV Ratings under parental control settings and setup password lock.
Language	English / Deutsch / Francais / Italiano / Español / Português and Pycckññ. 繁體中文 / 簡中	Switches the OSD language
Default		Resets OSD setting to default.

Setting the Channels

After you finish connecting your TV, you can run Auto Scan program to setup your channels. The program will scan and preset all receivable channels automatically.

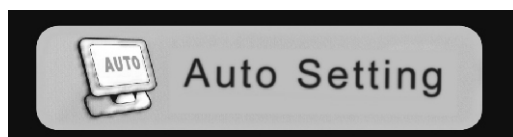

To Cancel Auto Program

Exit auto scan program by pressing "menu" Key.

Note: The Auto Scan is set to scan cable TV channels by default. You cannot receive and set the cable TV channels VHF/ UHF channels at the same time.

Setting Favorites Channels

You can select and store a list of your favorite channel settings. Selected favorite channels are marked with a  icon.



You can preset favorite channels on this page. You can also access this function by pressing the " FAVORITE " hotkey on the remote control and select or switch between your favorite channels .

1. Enter "Channel-Favorite" mode.
2. Press "Edit " to enter the channel(s) using the number keys.
You can "Delete" channels per line or "Empty" all channels at once.
3. Press "View" to see the selected channel display in real time.
4. Press "Enter" to exit when complete.

Watching favorite channels

To watch your favorite channels after specifying your preferences, just press the Hotkey "FAVORITE" to browse through each favorite channel.

Editing Channels

You can also edit channels to your personal preference. Once you edit a channel, it will be skipped when surfing through TV channels.

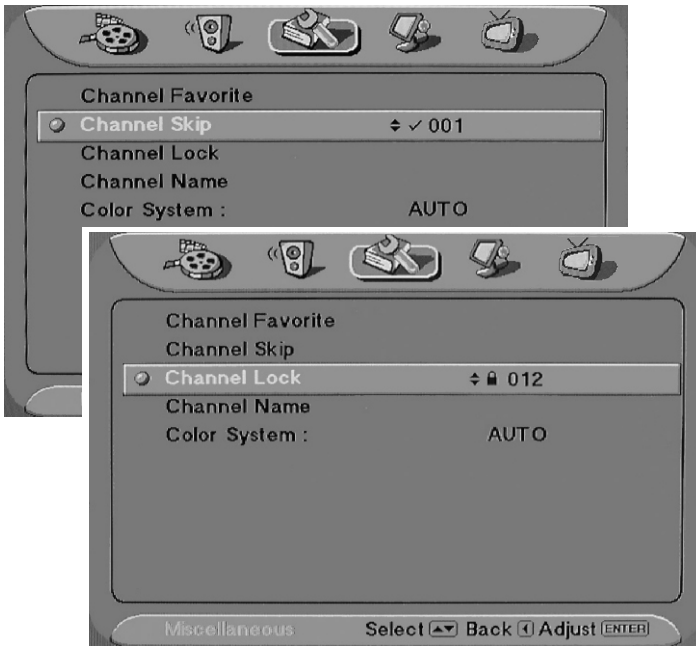

To Skip or Lock a Channel

1. Make sure Channel Skip or Channel Lock is highlighted.
 2. Enter the channel number you wish to skip or lock, or scroll through channels using the ▲ and ▼ Arrow.
 3. Press "Enter" to make your selection or adjustment.
- Note:** You will see a checkmark next to Skipped Channels, and a small lock icon next to Locked Channels.
4. Press ◀ to exit when complete.

To Undo a Skipped or Locked Channel:

1. Make sure Channel Skip or Channel Lock is highlighted.
 2. Enter channel number you wish you undo, or scroll through channels using the ▲ and ▼ Arrow.
 3. Press "Enter" to make your selection or adjustment.
- Note:** You will NOT see a checkmark next to Skipped Channels, or a small lock icon next to Locked Channels afterwards.
4. Press ◀ to exit when complete.

Personal Channel Preferences: Channel Naming

You can also create personal names for each channel, which will show up in the upper Right hand corner of the TV screen.

To Name a Channel:

1. Enter Channel Name sub-page
2. Enter Channel name using alphabet-numerical keypad as seen below:



3. Press "Okay" to exit keypad when naming is complete.

Once you have named a channel, your preset channel name will show up on the TV screen when flipping through channels, or by pressing the Display Key.



If you named your favorite channel, you will see the heart icon  next to the channel name.

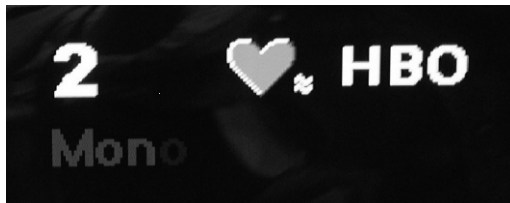

Setting up the TV Timer



To setup the time on the TV:

1. Using ▲ and ▼ keys, enter in HH: MM: SS. Enter the time using the number keys found on the remote.
2. press "Enter" when complete.

NOTE: Clock will NOT BE affected when Factory Default settings are reset. Under Activate, "ON" allows the start/stop time to be ongoing whereas, "ONCE" allows it to only function once.

However, when the power cord is not connected to the TV, you will lose all previous time adjustments.

Timer: Start Time / Stop Time

You can set the TV to turn On and/or Off automatically at a predetermined time through the timer function. Use the Start Time to setup the hour and minute preferences. Your TV will automatically turn on at the set time. Use the Stop Time to setup the hour and minute preferences. Your TV will automatically turn off at the set time.

Note: Alarm WILL BE affected when Factory Default settings are reset.

When the power cord is not connected to the TV, you will lose all previous saved adjustments.

Watching with Closed Caption



You can display closed captioning if the broadcaster offers this service.

Close Caption option can be set On/Off from the OSD page. This function also can be accessed by pressing "C.C" hotkey on the remote control.

1. Not all programs offer the Closed Caption option.
2. Closed Caption may not be seen clearly (white blocks, strange characters, etc.) if the signal condition is poor, or if there are technical difficulties with the broadcaster.
3. If no TEXT broadcast is being received while viewing in the [TEXT] mode, the screen may become dark and blank for some programs. Switch Off the Closed Caption mode.

TV OSD Languages

There are nine language formats available for the OSD Menu. You may choose from the following:

English, Chinese Traditional, Chinese Simplified, Deutsch, Francese, Italiano, Español, Português and Русский.



Using the Parental Control Feature

To block programs you feel unsuitable for your children, you need to Set the TV for desired rating systems. The TV Parental Control feature functions by receiving the rating signal from your local broadcasting station or cable service provider.

The TV programs and movies shown on TV are given a rating signal based on the following rating systems.

In U.S.A.: U.S. Television Parental Guidelines to rate television programs (U.S. TV Ratings) and Motion Picture Association of America (MPAA) Guidelines to rate movies including those shown on TV (Movie ratings).

In Canada: Canadian English Language ratings to rate television programs in English, and Canadian French Language ratings to rate those in French.

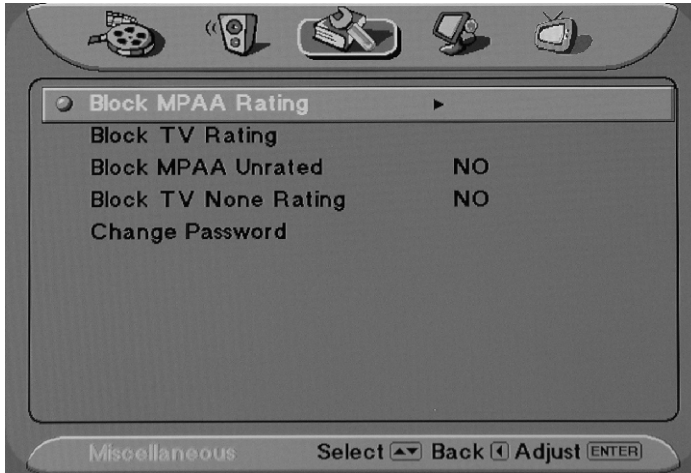

Parental Control

1. This function allows programs to be restricted and controlled by parents based on FCC regulation. It prevents children from watching program contents that may be prohibited by parents.
2. Restriction of programs is based on three Rating Systems: MPA Rating, TV (Child) Rating and TV (Entire Audience) Rating. The MPA Rating restricts based on age. TV (Child) rating and TV (Entire Audience) Rating restrict based on age and contents.
3. When you block the lower rating, the higher age-based ratings are blocked automatically.
4. When you enter "Parental control" mode, those messages display for different state.

The Parental Control Main Menu contains four options in the following categories:

- 1.MPA Rating
- 2.TV Rating
- 3.MPA Unrated
- 4.TV Unrating

Activating the Parental Control Feature

Once you enter the highlighted section of Parental Control, you will have to enter your password. The Factory Default password is "9999". Once you enter the Parental Control Menu, you may change the password to your personal preference.



To setup, enter each sub-menu to setup your parental controlled TV channels.

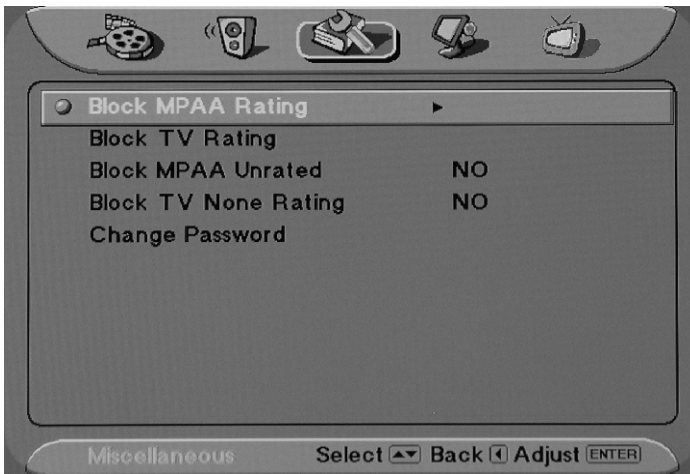

MPAA Rating controls channels and movies that are rated from **G**, **PG-13**, **R**, **NC-17**, and **X**.

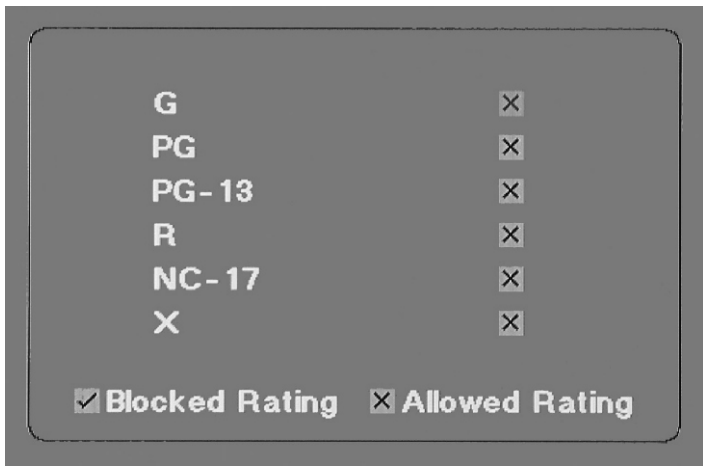

TV Rating controls channels and movies that have been rated from **TV-Y**, **TV Y-7**, **TV-G**, **TV-PG**, **TV-14**, and **TV-MA**.



Blocking Unrated Channels

You may choose "YES" for Block MPAA Unrated and Block TV None Rating. This will lock you from accessing any channels that do not contain MPAA or TV Ratings. To watch unrated channels, re-activate Block MPAA Unrated and Block TV None Rating to "NO".

Setting up Parental Control Password

Enter the password sub-page. Enter the current password. If this is the first time, you do not have to enter a password.



You will have to enter and confirm your password before changing to a new password. Please keep password within 4 numbers.



If you enter the incorrect password, you will see an error page. Please re-enter the new password and confirmation password again.

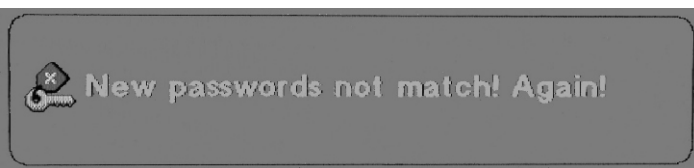

Note: If you forget the password, press "9999" to lift the Password lock and change to a new preferred password.

Factory Default Option



Reset Factory Settings:

Initiating Factory Default will reset all OSD settings to original manufacture settings. The only items, which will remain unaffected are:

- Clock
- Auto Scan Channels
- Edited Channels
- Parental Control Password

Adjusting Screen Modes

There are two options in Screen Mode, "Aspect & View". Aspect will allow user to select different aspect ratios, whereas the View function will display different modes of viewing between 2 different sources.



Changing the Screen Mode



You can alter the aspect ratio of a picture by choosing between these four options:

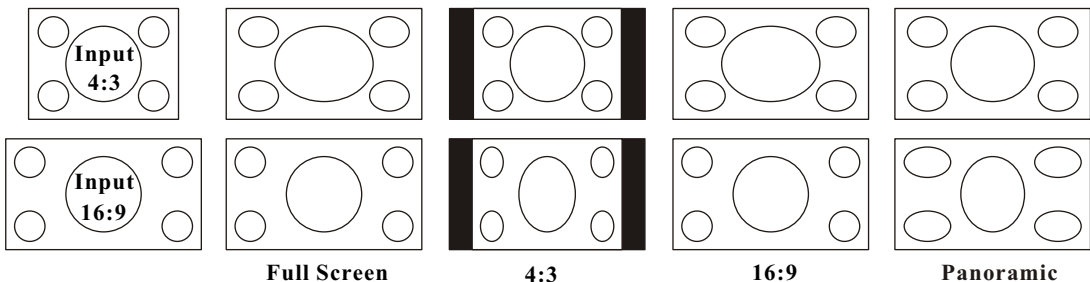

Full Screen Enlarges the picture to 16:9 wide mode, by stretching the picture horizontally only.

4:3 Returns the 4:3 picture to its original size. This is considered the "normal" viewing mode.

16:9 Enlarges (zoom-in) the size of a 4:3 picture on screen as geometric ratio, keeping the original image as much as possible.

Panoramic select to widen the displayed image. (only applies to content larger than 16:9)

Changing the View Modes

You can select four view types of picture modes that best suits the program you are watching. You can set a different view mode for each video mode for each input and store it manually.



View Modes	Function
PIP	Picture-in-Picture has a Main screen and small screen view
Split Screen	Full Screen split in two Views

Picture in Picture (PIP)

Allows you to view a main screen (Picture 1) and a secondary small screen (Picture 2).

Press 'source' button to switch from P1 to P2 and vice versa.

You may also choose the settings of P1 and P2 as well as the position of P2 on screen.

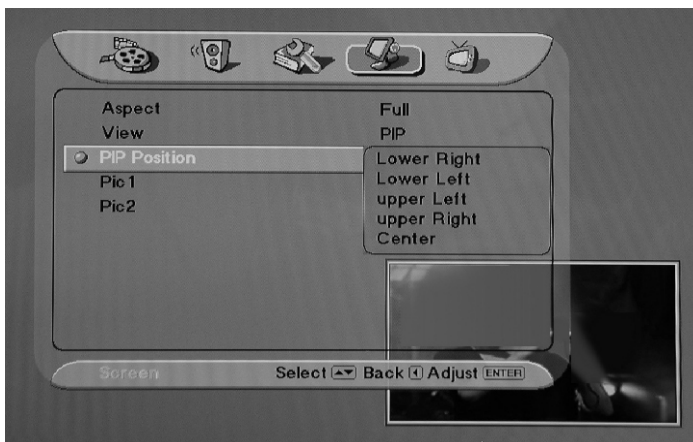

OSD View

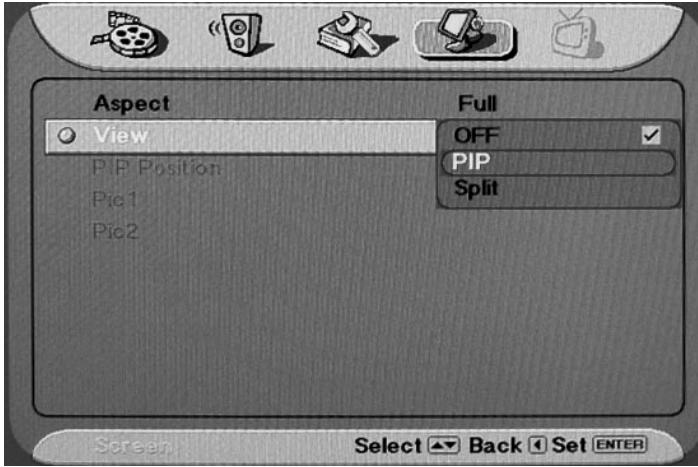

TV View

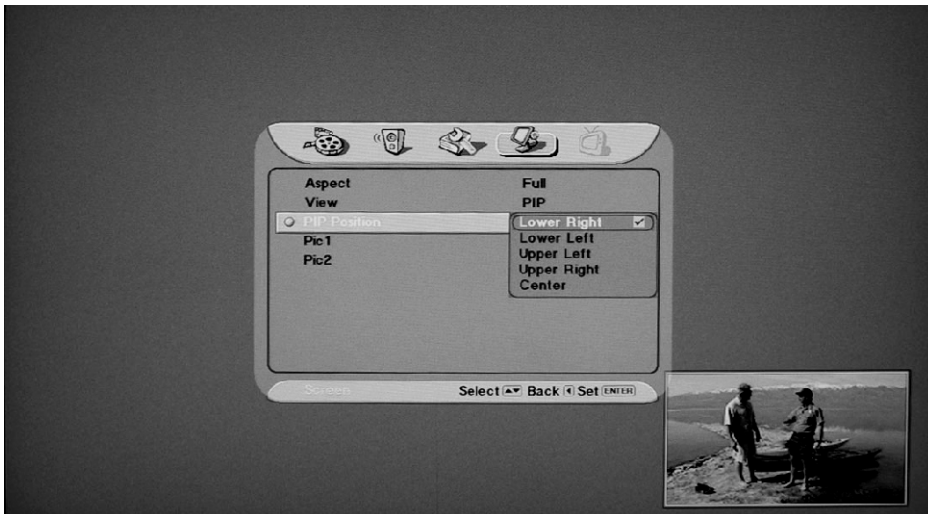

PIP Mode

You may adjust setting for each Picture source. Only Pic1 supports a TV input source, while Pic2 supports all other TV input sources.



Item	Adjustment	Function
PIP Position	Upper Left / Upper Right / Lower Left / Lower Right	Changes the position of Picture 2

PIP-Pic1 PIP-Pic2	TV 1	AV 1	AV 2	S-Video 1	S-Video 2	YPbPr 1	YPbPr 2	HDMI	VGA	DTV
TV 1	×	●	●	●	●	●	●	●	●	●
AV 1	●	×	×	●	●	●	●	●	●	●
S-Video 1	●	●	●	×	×	×	×	●	×	●
YPbPr 1	●	●	●	×	×	×	×	●	×	●
HDMI	●	●	●	●	●	●	●	×	●	×
VGA	●	●	●	×	×	×	×	●	×	●
DTV	●	●	●	●	●	●	●	×	●	×

For example: While selecting "TV" as PIP-Pic 1 source, the other available sources except "TV" can be selected as PIP-Pic 2 source.

When you use the swap function, the signals from the main window and the PIP window will swap positions no matter what sources you specified on either window.

Split Screen

Allows you to view two separate screens simultaneously (Picture 1 and Picture 2).

Press 'source' button to switch from P1 to P2 and vice versa.

OSD View



TV View

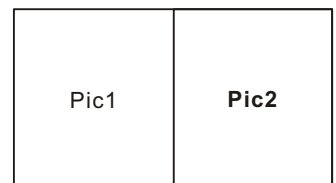
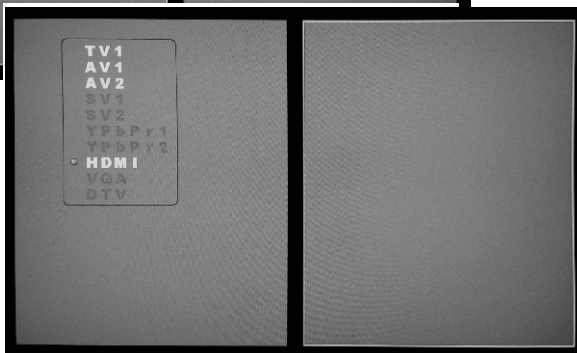

Split Screen Mode

You may adjust setting for each Picture source. Only Pic1 supports a TV input source, while Pic2 supports all other TV input sources.

Pic1 Pic2	TV 1	AV 1	AV 2	S-Video 1	S-Video 2	YPbPr 1	YPbPr 2	HDMI	VGA	DTV
TV 1	×	●	●	●	●	●	●	●	●	●
AV 1	●	×	×	●	●	●	●	●	●	●
S-Video 1	●	●	●	×	×	×	×	●	×	●
YPbPr 1	●	●	●	×	×	×	×	●	×	●
HDMI	●	●	●	●	●	●	●	×	●	×
VGA	●	●	●	×	×	×	×	●	×	●
DTV	●	●	●	●	●	●	●	×	●	×

For example: While selecting "TV" as Pic 1 source, the other available sources except "TV" can be selected as Pic 2 source.

When you use the swap function, the signals from the main window and the PIP window will swap positions no matter what sources you specified on either window.

DTV: Adjusting DTV Settings



Introduction to DTV

A Brief Look at Broadcast and Digital Television

Broadcast television is a traditional way of watching TV programs simply by installing an antenna. This is called analog TV. In recent years, many countries have begun to mandate a transition from analog to digital television. Digital TV provides noise-free, high-definition picture quality, Dolby AC-3 sound effects, and a handy EPG (electronic program guide). And the 16:9 video format gives a wider view than the traditional 4:3 format. Many TV broadcasters are now delivering digital TV programs, so switching to a digital HDTV receiver now makes good sense.

Digital TV programs are broadcast on both VHF and UHF frequency bands. Traditional analog TV uses one frequency channel to carry a single station's program. With digital TV, one frequency channel can carry up to four station programs. For example, analog channel CBS 2 may have become 2-1, 2-2, etc. when broadcast in digital TV. Channel 2 is the major channel and channel -1, -2, etc. are the sub-channels.

Digital TV signals are transmitted in either free-to-air (FTA) or pay-per-view (PPV) mode. FTA programs are received free with an MPEG 2-ATSC compliant digital receiver, such as the HDTV-ST. PPV programs can be received only by paying an access fee to the broadcaster and by using a digital receiver incorporating a compatible conditional access system. In addition, the HDTV-ST lets you watch HDTV, EDTV, and SDTV digital TV programs.

- ***HDTV** stands for High Definition Television; the common video formats are "1920 x 1080 interlaced" and "1280 x 720 progressive".
- ***EDTV** stands for Enhanced Definition Television; the common video format is "720 x 480 progressive".
- ***SDTV** stands for Standard Definition Television; the common video format is "720 x 480 interlaced".

DTV Functions

The HDTV-ST Digital HDTV Receiver can receive channels from both VHF band and UHF band TV signals. All the major free-to-air station numbers currently available in your area are listed in the on-screen menu. To watch the channel, simply select the channel number.

The receiver is fully ATSC / MPEG-2 (digital video broadcast) compliant, delivering High Definition crystal-clear video and Dolby AC-3 sound. It supports a radio signal range from 50-860 MHz, so all the channels within the VHF and UHF bands can be easily programmed. It can receive major and sub-channels containing both video and audio programs.

The receiver can receive hundreds of channels simply by selecting alternate TV channel frequencies in your area. To find out the specific digital TV services available to you, please contact your local service provider or log onto the website "<http://www.antennaweb.org>" With the wide range of features and HDTV programs open up to you by the HDTV-ST receiver, you'll be ready for a new era in home theater entertainment.

Summary Of Features

The receiver supports digital functions that are fully ATSC / MPEG-2 compliant and can store up to 2,500 digital channels. It can also receive Free-to-Air digital TV programs transmitted from all the available VHF and UHF Band signals in your area. Follow the on-screen display (OSD) to guide you through the steps necessary to configure your receiver. Then begin enjoying all the video and audio channels with crisp picture quality and the crystal clear sound.

The key features of the HDTV-ST Receiver are described below.

Remote Control The remote control provides access to the full range of system features. In addition to providing access to TV programs with channel and volume controls, it can be used to operate all the system menus. You must use the remote control to configure the channel settings, select the channels you want to include in the program list and access many other configuration options.

System Menus All the receiver's features can be accessed through the system menus by simply pointing and clicking. You can navigate through all the options in the menu and press "Select" button on the remote control or "Enter" button on the front panel.

The menu includes items such as Channel Configuration, Channel List, Audio Options, and Parental Lock.

Parental Locks Access to certain channels with content that might not be suitable for younger viewers can be controlled by password. Program ratings are shown on the I-Plate, which can be activated by pressing the "P.CTRL" key on the remote control. By pressing the "P.CTRL" twice, you can access the extended program information for the current channel.

Setting up the DTV Receiver

From your DTV OSD Menu, you can personalize your TV options in the following settings:

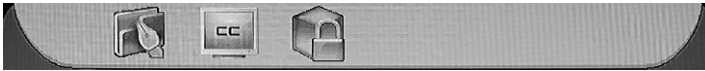

General Caption Parental

NOTE: Before setting the DTV OSD Menu, press the "SEARCH" hotkey on the remote control, and then press ▼ button to select and switch to DTV channel in advance.

General

Initial Screen

Before you can use any of the channel buttons (CH▲▼, FAV.), the available channels must first be scanned and memorized.

The first time the receiver is powered on, you will see the message "**Please Scan Channels**". Then do the following:

1. Press the "MENU" key, and then press ► button to select "DTV" icon.
2. Press the "ENTER" button, and then press ► button to enter the main menu.
3. On the "General" menu page, press▲ or▼ button to select "Auto/Manual Scan". Then press the "ENTER" button to scan channels.
4. Press the "EXIT" button to return to the previous menu or press the "MENU" button to exit the menu system.

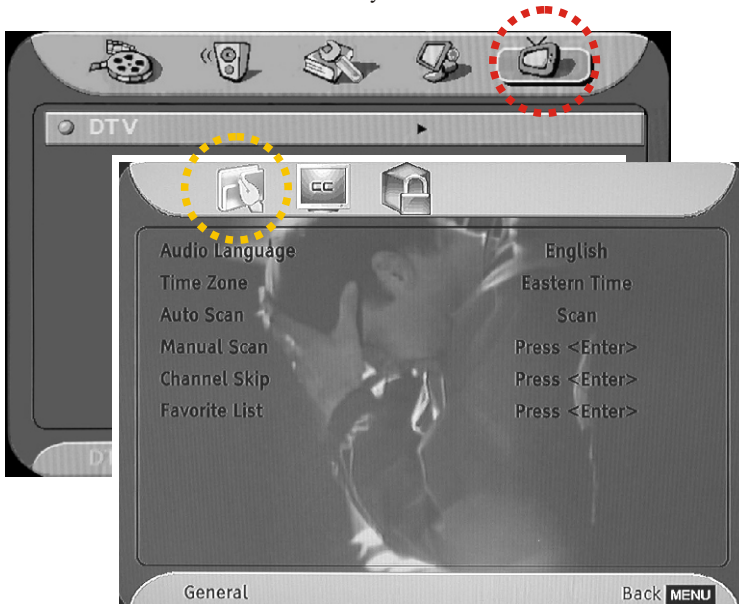

Audio Language

There are three language formats available for program broadcasting. You may choose from: English, Español, Français...,etc.

1. On the "General" menu page, press the "ENTER" button to enter the main menu.
2. On the "Audio Language" item, press ◀ or ▶ button to select your preferred language.



Time Zone

You can select available time zone where you live using the following step:

1. On the "General" menu page, press ▲ or ▼ button to select "Time Zone".
2. Press ◀ or ▶ button to select the available "Time Zone".

NOTE: If you are receiving a digital signal, the Receiver's time will be set automatically.

3. Press the "EXIT" button to return to the main menu or press the "MENU" button to exit the menu system.

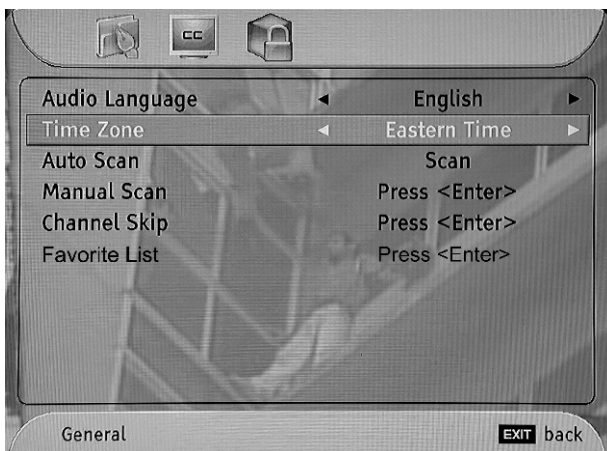

Auto Scan

To automatically scan your channels, follow these steps:

1. On the "General" menu page, press ▲ or ▼ button to select "Auto Scan", and then press the "ENTER" button. An Auto-Scan window will display the SCAN status.
2. Once the digital TV signal is scanned, the total number of found channels will be shown in the upper of the scan status bar.
3. It takes about three minutes to complete the entire scanning process.
4. Press the "EXIT" button to return to the main menu or press the "MENU" button to exit the menu system.

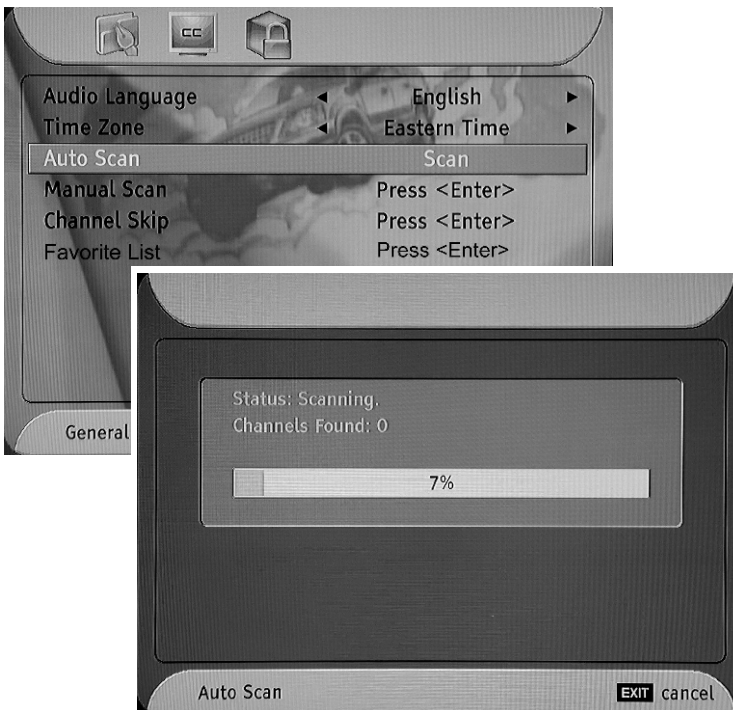

Manual Scan

Add-on Mode:

You can add channels manually if they aren't detected by the Auto Scan utility using the following steps:

1. On the "General" menu page, press ▲ or ▼ button to select "Manual Scan", and then press the "ENTER" button to enter the sub-menu.
2. Press the ◀ or ▶ button to select "Add-on Mode".
3. Press the "ENTER" button to start searching for the add-on channels.

4. Press the "EXIT" button to return to the main menu or press the "MENU" button to exit the menu system.

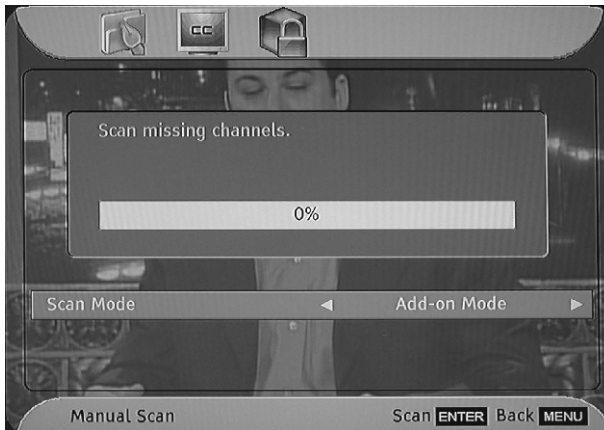
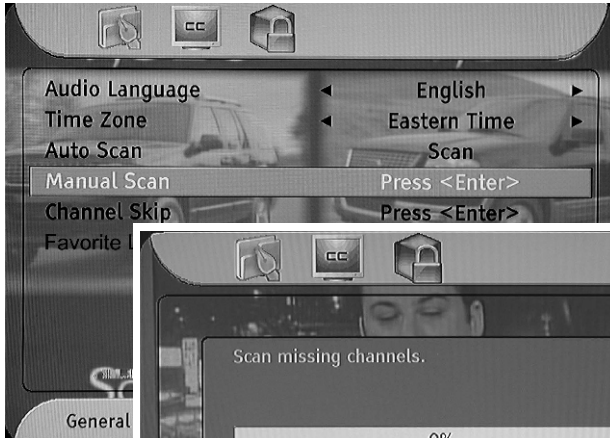

(Add-on Mode)

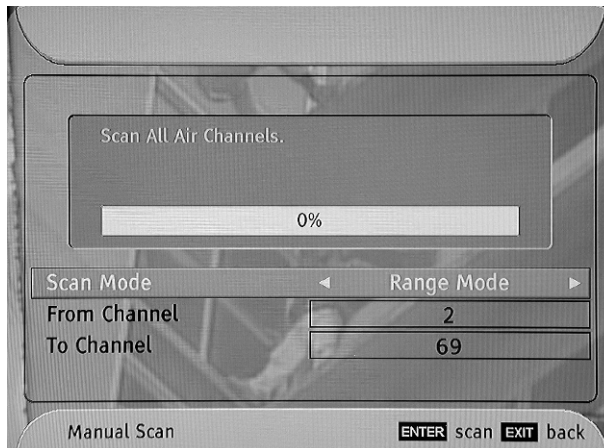

(Range Mode)

Range Mode:

The receiver scans Off-Air channels searching for both NTSC analog and ATSC digital signals from channel 2 to channel 69. The percentage bar shows the progress being made.

1. On the "General" menu page, press ▲ or ▼ button to select "Manual Scan", and then press the "ENTER" button to enter the sub-menu.
2. Press the ◀ or ▶ button to select "Range Mode".

3. Press the ▲ or ▼ button to highlight the input column, then press numeric buttons to input the channel number. The channel frequency is automatically shown on the input column.
4. Press the "ENTER" button to start searching for the channels within the range you select.
5. When it is complete, you can press the "EXIT" button to leave this window or press the "MENU" button to exit the menu system.

Channel Skip

You can skip the channel you hope not to view using the following step:

1. On the "General" menu page, press ▲ or ▼ button to select "Channel Skip" and press the "ENTER" button to enter the sub-menu.
2. Press ▲ or ▼ button to select the channel you wish to skip.
3. Press the "ENTER" button to skip or unskip the selected channel.
NOTE: You will see a checkmark next to the skipped channel after setting.
4. Press the "EXIT" button to return to the main menu or press the "MENU" button to exit the menu system.

NOTE: Once this function is set, the skipped channel will not display after searching. If you wish to view later, press the numeric keys on the remote control to input the channel number.

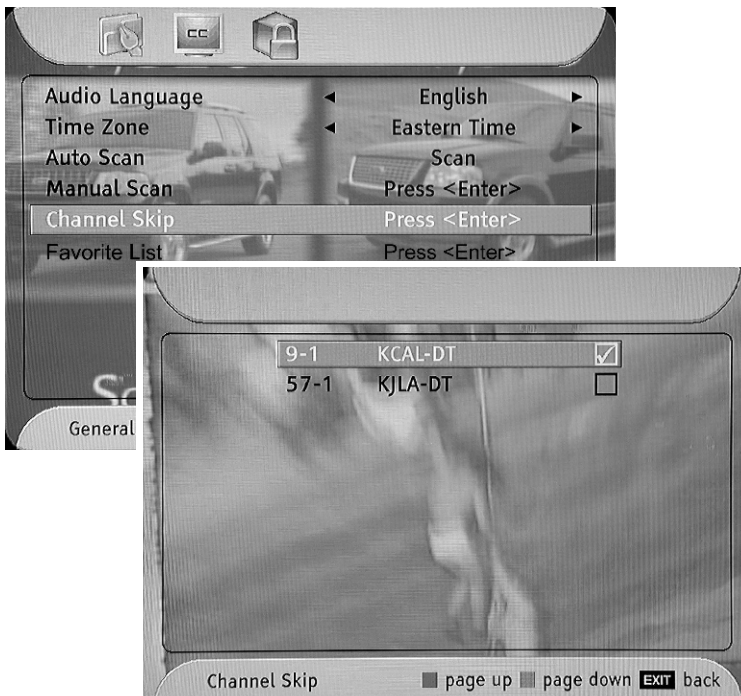

Setting Favorites Channels

You can select and store a list of your favorite digital channel settings using the following step:

1. On the "General" menu page, press ▼ button to select "Favorite List" and press the "ENTER" button to enter the sub-menu.
2. Press ▲ or ▼ button to select the channel.
3. Press the "ENTER" button to set your favorite channel.
NOTE: You will see a checkmark next to the selected favorite channel after setting.
4. Press the "EXIT" button to return to the main menu or press the "MENU" button to exit the menu system.

NOTE: You may also access this function by pressing the "FAVORITE" hotkey on the remote control to select or switch between your favorite channels.

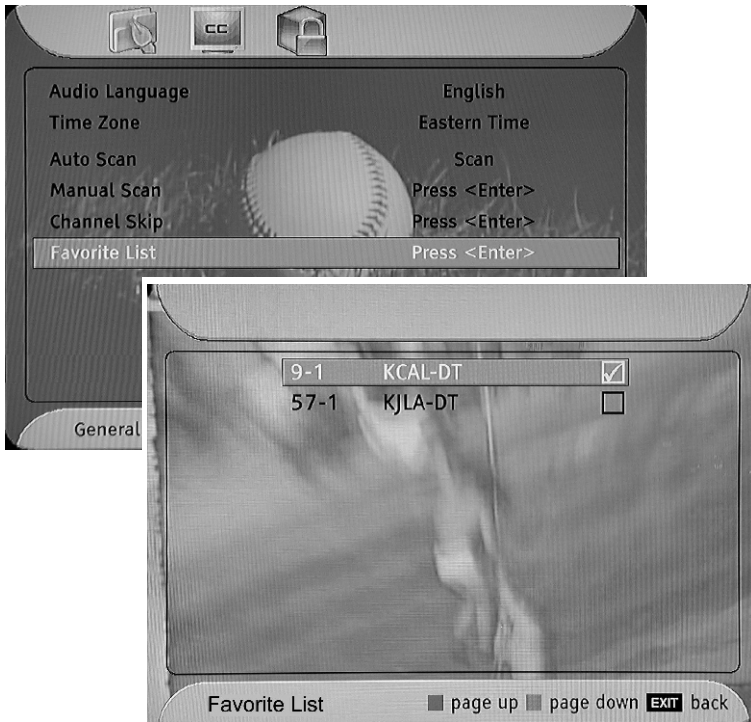

Closed Caption Options

While the program you are watching supports this function, it will allow you to read the voice content of TV program, such as the conversation or dialogue, with the text boxes shown at the bottom of the screen.

To turn on closed captioning, do the following :

1. Press ◀ or ▶ button to highlight the "Caption" icon.

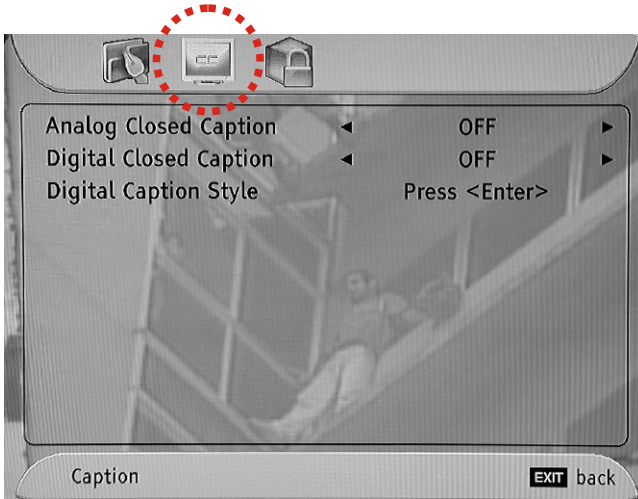

Description of Settings

Item	Adjustment	Function
Analog Closed Caption	Off, CC1, CC2, CC3, CC4, Text1, Text2, Text3, Text4	Selects the different types of closed caption shown on the traditional analog TV channels. CC1 : is used for most of programs. CC2 : may be used for alternate languages. Text : is used for the network and station information, such as channel guides, schedules, or bulletin board, for Closed Caption programs.
Digital Closed Caption	Off, Service 1~6	Selects the different types of closed caption shown on the digital TV channels.
Digital Caption Style		Selects the different styles of digital closed caption.
Caption Style		
As Broadcaster		
Custom		
Font Size	Medium, Large, Small	Selects the different font sizes of closed caption.
Font Color	Black, White, Green, Blue, Red, Cyan, Yellow, Magenta	Selects the different font colors of closed caption.
Font Opacity	Solid, Translucent, Transparent	Selects the different font opacity degree of closed caption.
Background Color	Black, White, Green, Blue, Red, Cyan, Yellow, Magenta	Selects the different Background colors of closed caption.
Background Opacity	Solid, Translucent, Transparent	Selects the different Background opacity degree of closed caption.
Window Color	Black, White, Green, Blue, Red, Cyan, Yellow, Magenta	Selects the different edge colors of closed caption.
Window Opacity	Solid, Translucent, Transparent	Selects the different edge opacity degree of closed caption.

Analog Closed Caption

If there is Closed Caption data shown on the current analog TV channel, you can select your preferred Closed Caption type using the following steps:

1. On the "Caption" menu page, press the "ENTER" button to enter the main menu.
2. On the "Analog Closed Caption" item, press ◀ or ▶ button to select the Closed Caption type.

Digital Closed Caption

If there is Closed Caption data shown on the current DTV channel, you can select your preferred Closed Caption type using the following steps:

1. On the "Caption" menu page, press the "ENTER" button to enter the main menu.
2. Press ▲ or ▼ button to select "Digital Closed Caption".
3. Press ◀ or ▶ button to select the Closed Caption type.

Digital Caption Style

If there is Closed Caption data shown on the current DTV channel, you can personalize the advanced Closed Caption Style using the following steps:

1. On the "Caption" menu page, press the "ENTER" button to enter the main menu.
2. Press ▼ button to select "Digital Caption Style", and then press the "ENTER" button to enter the sub-menu.
3. Press ◀ or ▶ button to select "As Broadcaster" or "Custom".
4. If you select "Custom" item, the advanced Caption Style settings will appear on the Caption Style window, and then press ▲ or ▼ button to select the item you wish to set.

● Font Size:

Press ◀ or ▶ button to select the font size of Closed Caption.

- **Font Color:**

Press ◀ or ▶ button to select the font color of Closed Caption.

- **Font Opacity:**

Press ◀ or ▶ button to select the font opacity degree of Closed Caption.

- **Background Color:**

Press ◀ or ▶ button to select the background color of Closed Caption.

- **Background Opacity:**

Press ◀ or ▶ button to select the background opacity degree of Closed Caption.

- **Window Color:**

Press ◀ or ▶ button to select the edge color of Closed Caption.

- **Window Opacity:**

Press ◀ or ▶ button to select the edge opacity degree of Closed Caption.

5. Press the "EXIT" button to return to the main menu or press the "MENU" button to exit the menu system.



Parental

Access to certain channels with content that might not be suitable for younger viewers can be controlled by password.

1. Press ◀ or ▶ button to highlight the "Parental" icon.

Password

1. On the "Parental" menu page, press the "ENTER" button to highlight the password input column.
2. Press the numeric key to input the password correctly.
(The default password is "9999".)
3. After the password is entered, the "Channel Block" screen will display. Then press the "ENTER" button to enter the sub-menu.
4. Press ▲ or ▼ button to select the channel you wish to lock.
5. Press the "ENTER" button to lock or unlock the selected channel.
NOTE: You will see a lock icon next to the locked channel after setting.
6. Press the "EXIT" button to return to the main menu or press the "MENU" button to exit the menu system.

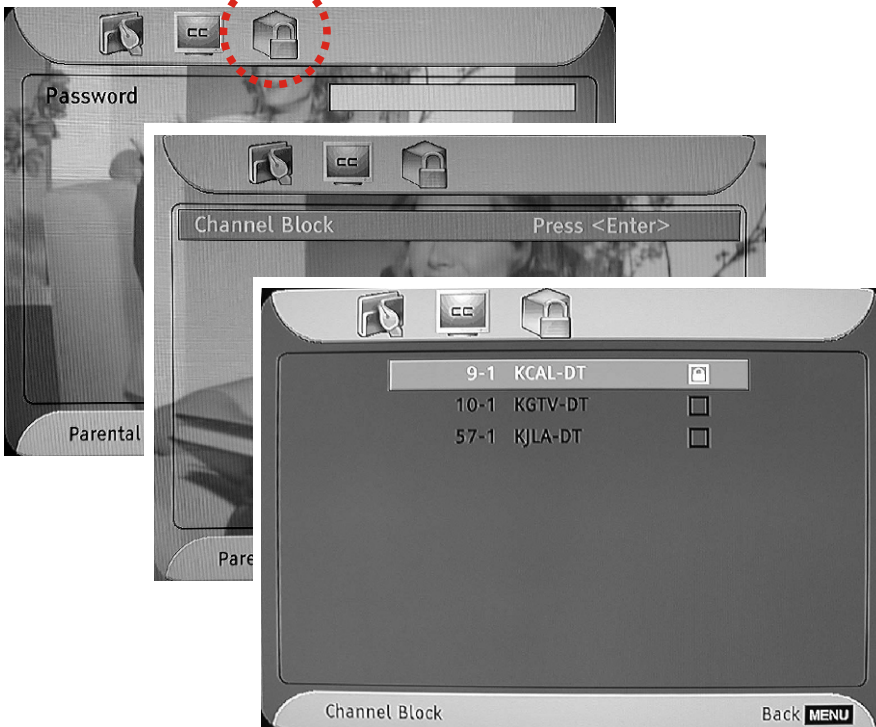

NOTE: If you wish to lock programs by rating, press the "P.CTRL" hotkey on the remote control. (For the details, please refer to Page 43-44)

Important information About "Parental Rating"

Explanation of the MPAA and TV (FCC) Rating Systems:

USTV (FCC) Age-Based Ratings

- TV-MA** Mature audiences only. This program may contain mature themes, profane language, graphic violence and explicit sexual content.
- TV-14** Parents strongly cautioned. This program may contain sophisticated themes, sexual content, strong language and more intense violence.
- TV-PG** Parental guidance suggested. The program may contain infrequent coarse language, limited violence, some suggestive sexual dialogue and situations.
- TV-G** General audience. The program contains little or no violence, no strong language, and little or no sexual dialogue or situations.
- TV-Y7** Directed to older children. Themes and elements in this program may include mild physical or comedic violence, or may frighten children under the age of seven.
- TV-Y** All children. The themes and elements in this program are specifically designed for a very young audience, including children from ages two to six.

USTV (FCC) Content Category

V Violence.	S Sexual content.
L Offensive language.	D Dialogue and sexual innuendo.
FV Fantasy or cartoon violence.	

MPAA Rating System (Movies)

- G** General audience. No restriction.
- PG** Children under 13 should be accompanied by an adult.
- PG-13** Parental guidance suggested. Children under 13 should be accompanied by an adult.
- R** Restricted. Viewers should be 17 or older.
- NC-17** Not classified. Viewers should be 17 or older.
- X** Adults only.

* USTV (FCC) ratings: When the rating that you select is locked (as indicated by the green lock symbol), all of the content-based ratings are locked within the rating group. For example, locking the TV-G rating locks all of its contents (V, S, L, and D). More restrictive ratings (TV-PG, TV-14, and TV-MA) and all of their contents are also automatically locked.

* MPAA ratings: The particular rating that you have selected will be locked. In addition, more restrictive ratings will be locked as well.

* Neither USTV (FCC) ratings nor MPAA ratings apply to news programs.

DTV Channel Table Information

*Log on to the website <http://www.antennaweb.org> and select "Choose An Antenna". Enter your address and find the DTV stations airing the EDTV / HDTV signal in your local area and then visit the local station websites for program schedules. Usually the website names are the same as the station's name. For example, DTV station WCBS (channel 56) New York's website is <http://www.wcbs.com> and KCET (UHF channel 59) Los Angeles's website is <http://www.kcet.org>.

However, the most accurate method for locating the local station's website is through their parent Network. For example, to find WCBS New York, check the CBS website. You can also contact the network service center for detailed information about their local DTV program package.

Note: (a) Using the Antenna Web site, you can also get information about choosing the correct type of antenna and the proper direction to point it toward the DTV station you want to watch.

(b) NAB (Association of Broadcasters) has updates on the local DTV stations in operation at <http://www.nab.org/Newsroom/Issues/digitaltv/DTVstations.asp>

Info (Information-Plate)

When you are watching digital channels, you can view the current program name and relevant information by pressing the "DISPLAY" hotkey on the remote control to show the I-Plate window on screen.

Current Program

1. After pressing the "DISPLAY" hotkey once, the I-Plate appears including this information:
 - TV Station Name
 - Current Channel Number
 - Program Name
 - Program start and end time
 - Picture resolution
 - Closed Caption
 - Audio System (Dolby 5.1 or PCM)
 - Program Rating Information
2. Press the "DISPLAY" hotkey twice to show extended program information for the current TV channel.
3. Press the "DISPLAY" hotkey once again or "EXIT" hotkey to cancel the I-Plate or extension window.

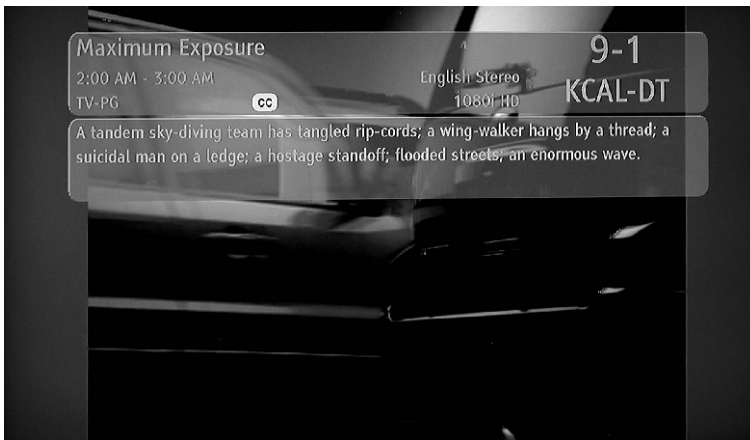

Next Program Information

If you wish to view the other program information, using the following steps:

1. Press ▼ or ▲ button to select the NEXT or PREVIOUS program.
2. Press the "DISPLAY" hotkey to show the I-Plate window on screen.
3. Press the "EXIT" hotkey to exit the I-Plate window on screen.

Setting Favorite Channels

When you are watching broadcast or cable TV channels, you can use the "ADD/ERASE" shortcut key to set the Favorite Channel.

1. Press the "ADD/ERASE" hotkey on the remote control to add or erase the Favorite Channel.
2. An  icon will display on the I-Plate window after setting the current channel as the Favorite Channel.
3. Press the "Favorite" hotkey on the remote control to select or switch between your favorite programs.



Selecting Digital Channels

Selecting digital channel numbers is different from selecting traditional channel numbers.

For example, To select digital channel number: 10-2

1. Press the numeric key "1" and "0".
2. Press the "-" button.
3. Press the numeric key "2".

Watching with Closed Caption

You can set the Closed Caption type if the broadcaster supports this service.

1. Press the "C.C" hotkey repeatedly on the remote control, then the "C.C Pop-up Bar" will appear on the window for your settings.



Freezing the Picture

1. Press the "FREEZE" button on the remote control to freeze the picture.
2. The "Freeze" message will appear in the upper left corner of the screen.
3. Pressing the "FREEZE" button again will release the picture.

NOTE: If you freeze a program for purposes other than personal viewing, you may infringe on the program's copyright.

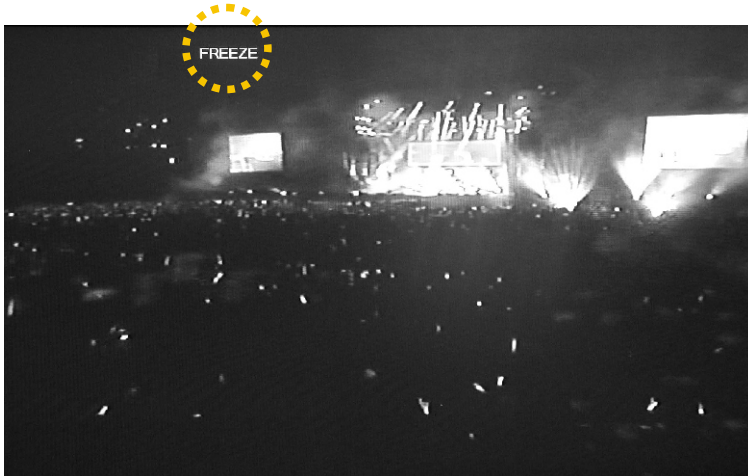

MTS System for Stereo TV

You can use the "MTS" hotkey repeatedly on the remote control to select the TV Audio System among Mono, Stereo, SAP for the analog TV program.

Audio System	Description
Mono	Select for mono reception. (Use to reduce noise during weak stereo broadcasts)
Stereo	Select for stereo reception when viewing a program broadcast in stereo mode.
SAP	Select to automatically switch the TV to Secondary Analog Program when a signal is received. (If no SAP signal is present, the TV remains in stereo mode)



Or

You can use this hotkey to select one Audio Language for the digital TV program.



WM30D Wall Mount Kit (Optional)

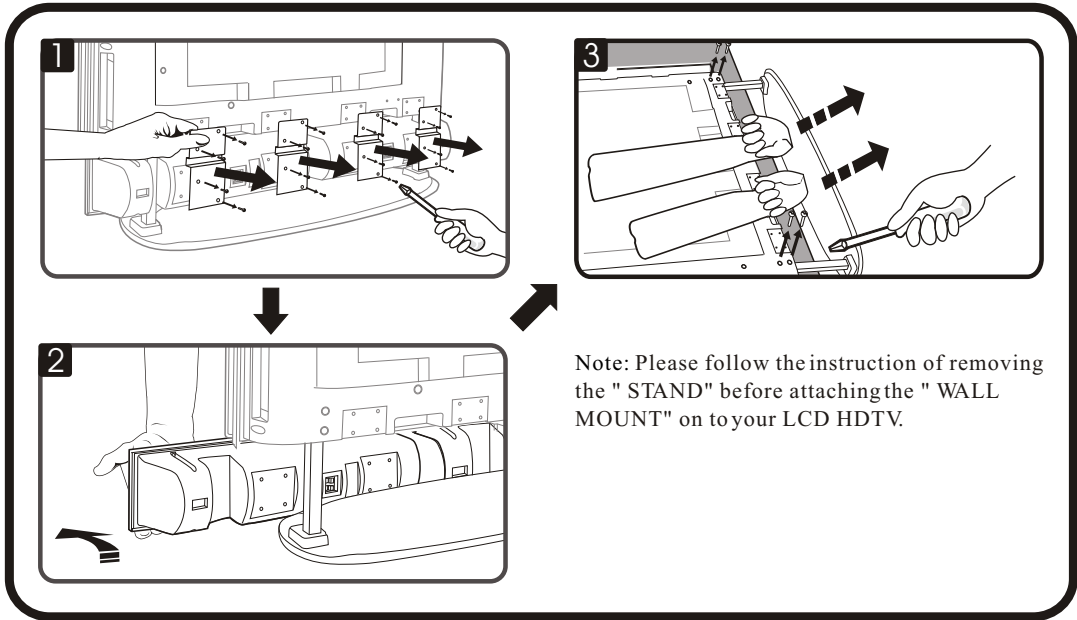

Note: Please follow the instruction of removing the "STAND" before attaching the "WALL MOUNT" on to your LCD HDTV.

1. Before using wall mount, please read manual of wall mount and following assembly guide.
2. For safety purpose, please purchase wall mount which can bear the LCD HDTV weight.
3. Following installation instruction is only for your reference.
4. Please consult authorized service personnel for the installation of wall mount.

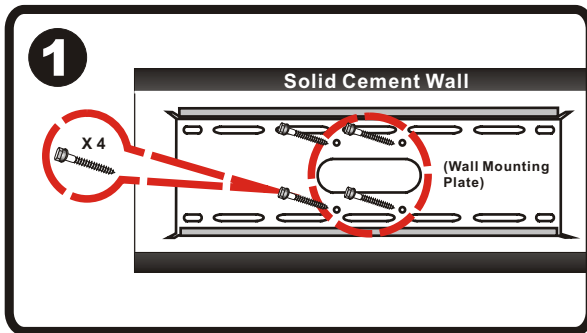

1. Pre-drill four of the 3/16" (5 mm) holes on the solid cement wall.

2. Level and secure the wall mounting plate to the center of the solid cement wall using the four lag bolts and washers supplied.

Note: Please make sure the solid cement wall can burden with the weight of the unit at least 4 times.

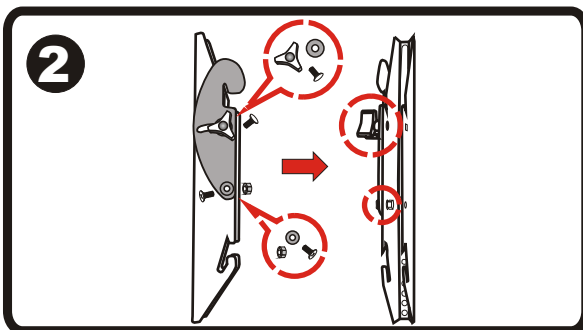

1. Secure two iron plates of the display bracket together with the screws, lock washers, and tri knobs supplied and then tighten them.

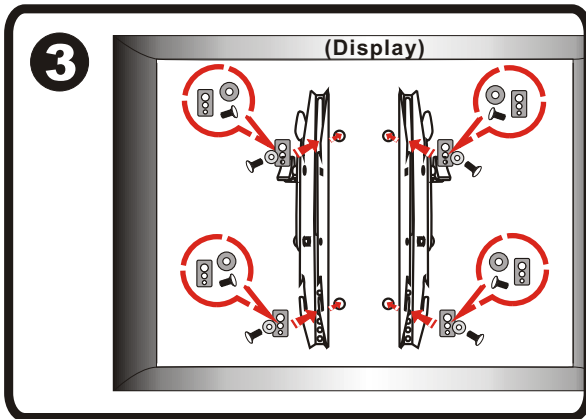

1. Lay the display panel, face down on a protected surface.

2. Aim at the display wall mounting holes vertically with the left and right display brackets.

3. Using the screws, lock washers, and square multi-mount washers supplied to secure the display brackets to the display and them tighten them.

Note: Do not over tighten the bracket mounting screws.

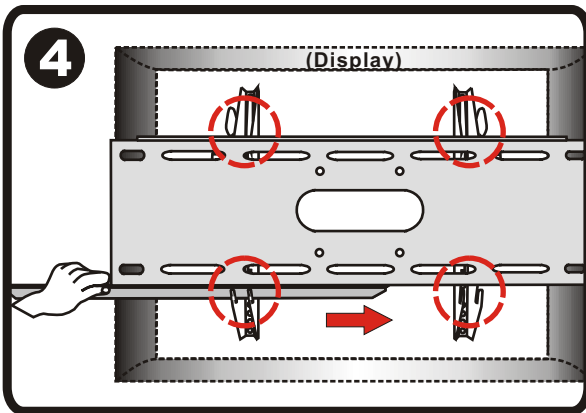

1. Lift the display with the brackets attached onto the wall mounting plate.

2. Make sure the top and bottom of the wall mounting plate are placed into the display brackets slots.

3. Insert the locking bar from left to right direction with the locking holes facing up to match the holes in the wall mounting plate.

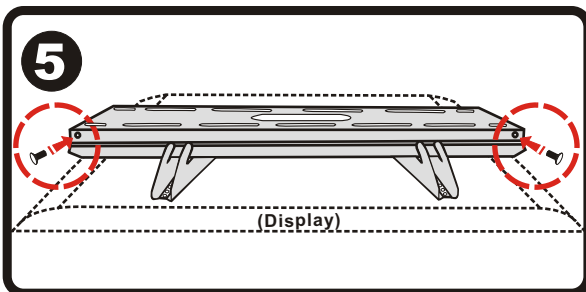

1. Using the screws to secure the locking bar and the wall mount plate and then tighten them.

2. Make sure the display brackets engage the rails on the wall mount plate.

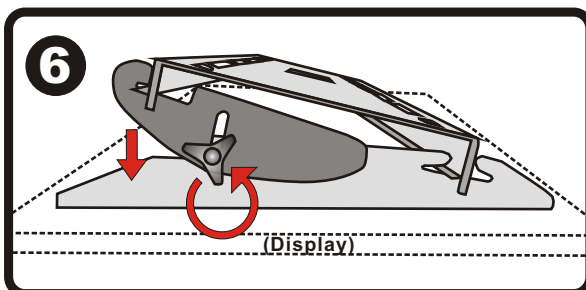

1. Turn both of the tri knobs on the display brackets.

2. Slide the unit attached on the display brackets gently to adjust the best viewing angle (up to 15 degree).

3. After the adjustment is complete, tighten both of the tri knobs.

Specifications

TFT LCD Panel

Specifications	
Panel Size	40"
Aspect Ratio	16:9
Pixels	1366 X 768
Brightness	500 Nits
Contrast Dynamic Ratio	1600:1*
H/V(View Angle)	178 ° (H) / 178 ° (V)
Gray to Gray Response Time	8 ms
Video/Graphic Processing	
PC Compatible Frequency	30~85 KHz(H) / 50~80Hz(V) Max. 1280x1024 @60Hz
Video Compatibility	NTSC
DTV & HDTV Compatibility	480i, 480p, 720p, 1080i
Aspect Ratio Adjustment	Zoom, Full Screen, 4:3, Panormaic
3D Comb Filter	Y
3 : 2 / 2 : 2 Pull Down	Y
Digital Noise Reduction	ON/OFF, High, Low
Adjustable Color Temperature	Cool, Normal, Warm
De-interlacer	Y
VGA Auto Frequency Correction	Y
TV Auto Frequency Detection	Y
Audio Processing	
Auto Sound Level Control	Y
Output Watt	20W + 20W
Sound Effect	MTS (Mono / Stereo / SAP)
Input Terminals	
TV Tuner	NTSC tuner x1 + ATSC tuner x1
Video Input(Rear Side)	Input 1:AV x1, S-Video x1, RL x1 Input 2:AV x1, S-Video x1, RL x1 Input 3:Y, Pb/Cr, Pr/Cr x1, RLx1 Input 4:Y, Pb/Cb, PrCr x1, RLx1
Graphic Input(Rear)	Input 1:RGB D-Sub 15 pin x1 Input 2:HDMI(DVI-D)x1 , RL x1
Service Port(Rear)	RS-232 mini DIN 6 pins X 1

* **NOTE** : Product Specification is Subject to Change without Notice.

TFT LCD Panel

Output Terminals

Audio Output(Rear)	Output 1: StereoAudio R/Lx1
Audio Output(Front)	Output 1: Earphone 1/8"

Others

Power	(Voltage)	100~240 VAC/ 50-60 Hz
	(Power Consumption)	250W
	Stand-by	< 3W
Dimensions (W xD x H)		39.33 in x 5.7 in x 32.08 in
Carton Dimensions (Wx D xH)		43.7 in x 15.15 in x 36.29 in
Weight		68.28 lbs
Weight w/ stand		85.9 lbs
Gross Weight		105.72 lbs

Dimensional Drawing

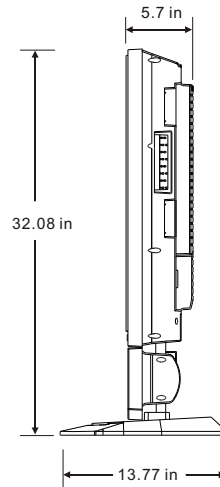
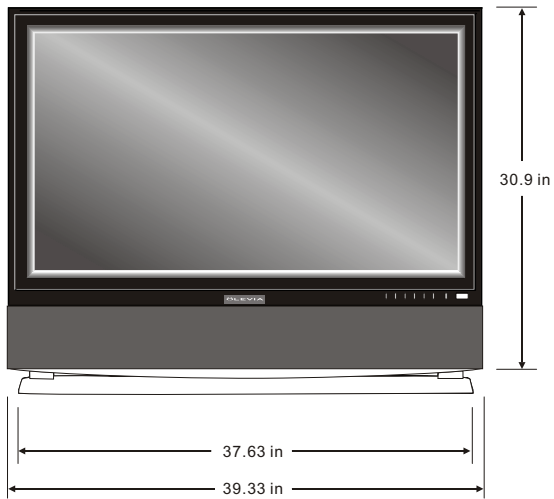

Timing Mode for VGA and DVI

Source	Resolution	Vertical frequency(Hz)	Horizontal frequency (Khz)	Pixel rate (MHZ)	
YPbPr	480p	59.94	31.469	27	
	720p	60	45	74.25	
	1080i	60	33.75	74.25	
VGA	512 x 384	60.147	24.48	15.667	
	640 x 350	85	37.861	31.5	
	640 x 400	85	37.861	31.5	
		56	24.823	21.05	
		59	30.296	24.964	
		640x480	59	30.295	25.024
		66	35	30.24	
	66	34.975	31.34		
	66	35	30.24		
	72	37.861	31.5		
	75	37.5	31.5		
	75	39.375	31.5		
	85	43.269	36		
	720 x 350	70	31.469	28.32	
	720 x 400	70	31.469	28.32	
		85	37.927	35.5	
		87	39.444	35.5	
	800 x 600	56	35.156	36	
		60	37.879	40	
		72	48.077	50	
		75	46.875	49.5	
		85	53.674	56.25	
	832 x 624	74.6	49.725	55	
	1024 x 768	59	48.193	64	
		60	47.699	64.1	
		60	48.363	65	
		70	56.476	75	
70		56.287	77		
71		57.87	75		
75		60.241	80		

Source	Resolution	Vertical frequency(Hz)	Horizontal frequency (Khz)	Pixel rate (MHZ)
VGA	1024 x 768	75	60.241	80
		75	62.937	84.6
		75	61.08	86
		75	60.023	78.75
		77	62.04	84.4
		85	68.677	94.5
	1152 x 864	70.012	63.851	94.5
		75	67.5	108
	1152 x 870	75.062	68.681	100
	1152 x 900	65.95	61.795	92.9
		66.004	61.846	94.5
		76.047	71.713	105.6
		76.149	71.809	108
	1024 x 1024	60	63.36	89.2
		61.399	65.286	92.9
	1280x 960	60	60	108
	1280 x 720	60	45	74.25
	1280 x 768	60	48.36	81.631
	1280 x 1024	60	63.981	108
	1366 x 768	60	47.7	85.8
DVI	1024 x 768	50.014	48.363	32.5
		56.041	48.363	32.5
	1280 x 720	60	45	74.25
	800 x 600	60.317	37.879	40
	1024 x 768	60.004	48.363	65
	1280 x 768	60	48.36	81.631
	1366 x 768	60	47.7	86

Pixels Policy

Syntax-Brilliant's D.O.A. Policy for LCD HDTV for Defective Pixels on LCD Panels

(Applicable to the LCD HDTV sold within USA & Canada only)

Syntax-Brilliant™ LCD HDTVs are evaluated at a distance of approximately 50 centimeters (approximately 20 inches) between the LCD panel and the eyes of the user at a 90 degrees viewing angle. All LCD panels have been tested to ensure they comply with our factory standards. Our evaluation is based on the number of defective pixels and the distance between any two defective pixels. Bright dots are dots that appear bright and unchanged in size when a LCD HDTV screen displays under a black pattern; dark dots are dots that appear dark and unchanged in size when a LCD HDTV screen is displayed under pure red, green, or blue patterns ("defective pixels"). Adjacent dots are dots located directly next to each other.

Customers are required to check their LCD panel immediately after purchase. To identify defective pixels, the LCD panel should be examined under normal operating conditions as mentioned above, preferably in its native display resolution, and with a 90 degrees viewing angle.

A LCD HDTV will be considered dead on arrival (D.O.A.) with regards to defective pixels on the LCD panel when any one of the following criteria is met:

- A total of 7 defective pixels including both bright dots and dark dots are present (the typical 30" LCD Television screen has 16.7 million pixels), or
- 2 or more pairs of adjacent bright dots are present, or
- 3 adjacent bright dots are present, or
- 3 adjacent dark dots are present.

In view of customers' concerns about dead pixels, Syntax-Brilliant™ would like to address that defective pixels are not ultimately avoidable with the current LCD industry standard panel manufacturing processes. We always strive to improve our technology and minimize the chance of occurrence of defective pixels by applying strict screening processes in our factory production processes. However, Syntax-Brilliant™ cannot guarantee that a return unit to our customers will be 100% free of defective pixels.

For questions, please call our toll free service number in the USA at 888-Syntax-Brilliant-8.

"At Syntax-Brilliant™ Groups, a satisfied customer is our most important focus."

Glossary

3:2 pull down - Process of converting 24 frames per second film to video by repeating one film frame as three fields, then the next film frame as two fields.

1	1	1	2	2	1	1	1	2	2
---	---	---	---	---	---	---	---	---	---

480I - 480 lines of display every 1/60 of a second; image is displayed by interlace scanning. See also Interlaced

480P - 480 lines of display every 1/60 of a second; image is displayed by progressive scanning. See also Progressive.

720P - 720 lines of display every 1/60 of a second; image is displayed by progressive scanning. See also Progressive.

1080I - 540 lines of display x 2 every 1/30 of a second; image is displayed by interlace scanning. See also Interlaced

16:9 - Aspect ratio under Hi Def. and theater movie formats. Also known as wide screen; see Aspect Ratio

4:3 - Aspect ratio under SDTV; see Aspect Ratio

Active Matrix TFT (Thin Film Transfer) - A type of display technology where the three primary colors are modulated. Results in better contrast ratios suitable for video.

Alarm - Feature on the Syntax-Brilliant Olevia models. Allows the unit to power on from the stand by mode.

Alarm Time - Time specified as to when the unit will power on. See Alarm.

Aspect Ratio - The ratio of an image according to the width and height of a picture.

ATSC - Advanced Television Systems Committee; international, non-profit organization that is committed to developing standards for digital television.

Reference: <http://www.atsc.org>

Bezel - Refers to the plastic or metal frame that acts like a shell around the LCD glass.

Backlight - Refers to the component, that lights up the LCD display.

Balance - Feature on the OSD for the Syntax-Brilliant Olevia models that adjust the left and right sound output from the speakers.

Background - Feature on the OSD for the Syntax-Brilliant Olevia models, which allows the user to change the OSD background, display to transparent or opaque.

Brightness - The measurement of color that is illuminated. Colors range from black to white.

CATV - Community Antenna Television (Cable Television)

Channel Favorite - Feature on the OSD for the Syntax-Brilliant Olevia models that allows the user to scroll through a defined list of channels that the user sets up.

Channel Edit - Feature on the OSD for the Syntax-Brilliant Olevia models that allows the user add or delete a channel.

Channel Source - Feature on the OSD for the Syntax-Brilliant Olevia models that lets the user select the source of their channels. Select TV for antennae or CATV for cable television.

Channel Auto Scan - Feature on the OSD for the Syntax-Brilliant Olevia models that when initiated, will determine which channels are available and which are not. If a desired channel is not accessible, you can add the channel in manually. See Channel Edit.

Channel Fine Tune - Feature on the OSD for the Syntax-Brilliant Olevia models that enables the user to tune the channel for better reception.

Chroma - (Chrominance) Refers to the color characteristics of a video signal.

CC - Closed Caption

Color - The term refers to the amount of color present. This varies between each user, as each person perceives colors differently.

Color Temperature - Feature on the OSD for the Syntax-Brilliant Olevia models that enables warm, normal or cool color settings. Warm emphasizes red, cool emphasizes blue, and normal doesn't emphasize any of the primary colors. This setting may affect each person individually depending on how color is perceived.

Comb Filter - A filtering system designed to removal unwanted artifacts by rejecting certain frequencies while permitting others.

Component - A three RCA type input that uses high quality cables (one for brightness, and two for color). Process increases bandwidth resulting in more color information to be carried to the TV producing a more accurate picture.

Composite - Also known as CVBS, Technology that permits the combination of color information and brightness under one wire. A single video signal that carries both brightness and color information are contained in a single wire.

Contrast - Difference in luminance between the white and black colors.

CRT - Cathode Ray Tube.

DB15 - Also referred to as VGA; See VGA

De-Interlace - Process of converting an interlaced video signal.

Display Area - The perimeter of the LCD glass the image is displayed on. See Video Resolution

Dual Link - See Single Link; Supports a maximum bandwidth of 2 x 165 MHz (1920 x 1080 @ 60 Hz, 1280 x 1024 @ 85 Hz).

DVI - Digital Video Interface Describes the technology that is used to take full advantage of a signal when paired with a high-end video card and flat panel displays

DVI-A - Digital Video Hi-Resolution Analog

DVI-D - Digital Video Interface Digital; Cable is used for direct connection from one digital source to the TV; See DVI

DVI-I - Digital Video Interface Integrated; Cable that supports analog and digital signals; See DVI

DTV - Digital Television

Factory Default - Feature on the OSD for the Syntax-Brilliant Olevia models that resets all menu options to factory default.

F-Connector - The standard connector found on video equipments that coaxial cables connect to.

Flat-Panel Display - ultra thin displays, usually found in notebooks are now entering the TV appliances sector as new technology enables wider/larger screens.

Frame - A complete picture that includes both even and odd lines. 30 video frames are present in 1 second.

Gain - Describes the amplification level of a particular signal.

HDCP - High bandwidth Digital Content Protection

HDTV - 1.High Definition Television 2. Designates as the unit having a built in ATSC tuner to decode High Definition signals (720P/1080I).

HD-Ready - A unit that supports the High Definition displays (720P/1080I) with the help of a Set-Top Box.

Horizontal Resolution - Refers to the number of vertical black and white lines defined along a horizontal line.

IR - Infrared

Input - term used in the On Screen Display

Interlaced - Images are the result of lines of data reassembled. Interlaced refers to the process of an image's odd lines reassembled from top to bottom taking about 1/60 of a second, before reassembling the even lines which results in a full picture. Antonym: Progressive

Language - Feature on the OSD for the Syntax-Brilliant Olevia models that enables the OSD to be read in different languages.

LCD - Liquid Crystal Display

LCoS - Liquid Crystal on Silicon

LED - Light Emitting Diode

Luminance - refers to the brightness of an image.

Lux - 1 Lux = 1 footcandle; measurement of brightness

Moire - A visual illusion in which a succession of parallel curved lines produces a pattern to the naked eye, but does not really exist. Otherwise known as the moire effect.

NCTA - National Cable Television Association

Noise reduction - Feature on the OSD for the Syntax-Brilliant Olevia models that enables channels from the tuner box to reduce noise displayed on the LCD unit.

NTSC - National Television systems Committee

OSD - On Screen Display; brought up by pressing the menu button on the TV or the Remote.

Over Scanning - An image displayed is larger than the display area

PAL - Phase Alternating Line

Parental Control - The ability to block access to specified content from an unsuitable audience.

PIP - Picture in Picture; feature that enables one source to be displayed on top of another source.

Pixel Resolution - Refers to the number of rows horizontal and vertical that produces the image.

PIP - Picture in Picture; Allows an image to be displayed in front of another image.

Plug and Play - Describes the hardware or software that is installed and does not require any configuration before using.

Progressive - An image or lines of data that is reassembled from top to bottom sequentially.

Antonym: Interlaced

RGB - Red, green & blue These primary colors provide the basis for many different colors.

Refresh Rate - Refers to the maximum number of frames that the monitor can display per second. Usually measured in hertz.

Saturation - The amount of a particular color present in an image.

SCART - An industry standard for interconnecting audio-video equipment developed by Peritel. Usually associated with PAL video equipment.

SDTV - Standard Definition Television usually in 480I/P format.

SECAM - Sequential Color with Memory or Sequential Couleur Avec Memoire

Set-Top-Box - box that is capable of receiving and decoding digital transmissions (i.e. High Definition Cable Box, Digital Cable box).

Sharpness - Tries to artificially enhance the edges of a picture.

Single Link - supports a maximum bandwidth of 165 MHz (1920 x 1080 @ 60 Hz, 1280 x 1024 @ 85 Hz).

Split screen - Feature that places two images side by side.

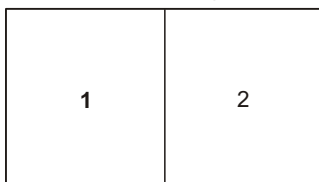

Swap - Button featured on the Olevia remote. Used in the POP3 or PIP12 views to swap the sub viewable boxes with the main viewable box.

Tint - Adjusts the whiteness level within the color. Similar to Hue.

Under- scanning Term used where the image displayed is smaller than the display area.

Up convert - Process of converting a 480P/I signals to 720P or 1080I.

V-Chip - Chip that controls access to forbidden content specified by an adult.

VGA - 1. Video Graphics Array (DB15) 2.

Video Display - Refers to the display resolution

Video Resolution

Aspect Ratio 4:3		Aspect Ratio 16:9	
VGA	640 x 480	WXGA	1280 X 800
SVGA	800 x 600	SXGA	1280 X 1024
XGA	1024 x 768	WXGA+	1400 X 1050
QVGA	1280 x 960	WSXGA	1680 X 1050
SXGA+	1400 x 1050	WUXGA	1920 X 1200
UXGA	1600 x 1200	QSXGA	2560 X 2048
QXGA	2048 x 1536		
QSXGA+	2800 x 2100		
QUXGA	3200 x 2400		

Viewable Angle - Angle at which the screen is still viewable.

Widescreen - See 16:9

YCbCr - Used often with standard interlaced video equipment. See Component

YPbPr - Used often with progressive video equipment. See Component