

42" CLASS (42.0" DIAGONAL)

M4212T-BA

LCD
MONITOR

Touch Screen LCD Widescreen HD Monitor



3M DST INTEGRATED TOUCH
With fast, accurate touch response

NATIVE DISPLAY RESOLUTION
1366 x 768 WXGA

LG'S EXCLUSIVE XD ENGINE®

CONTRAST RATIO
3000:1

178 DEGREE VIEWING ANGLE (S-IPS)
Super IPS™ technology allows for superior
viewing from almost any angle

HIGH BRIGHTNESS
500 cd/m²

9MS RESPONSE TIME

TEMPERATURE AND LAMP FAULT SENSOR

HDMI™ WITH HDCP

RoHS COMPLIANT

3-YEAR LIMITED WARRANTY
(parts/labor)

BROUGHT TO YOU BY

KRISTEL
DISPLAYS

www.kristel.com

 **LG**
Life's Good

www.LGcommercial.com

M4212T-BA

42" CLASS (42.0" DIAGONAL)

DIMENSIONS

SPECIFICATIONS

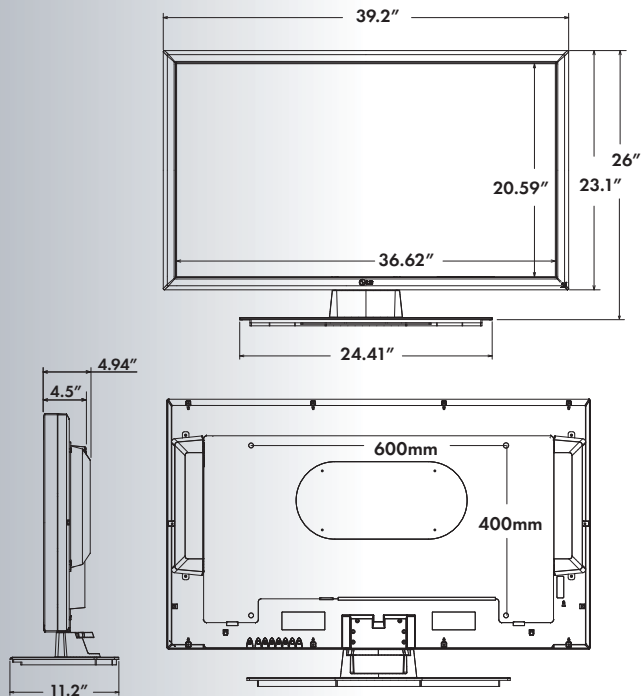

Note: Speakers and stand are optional accessories

Rear Jack Pack Panel



LCD PANEL	
LCD Panel Type	42" Widescreen TFT (Thin Film Transistor)
Display Area	42.0" diagonal
Touch Screen	3M DST Integrated Touch
Panel Type (TN/IPS)	SIPS
Aspect Ratio	16:9
Native Resolution	1366 x 768
Brightness	500 cd/m ²
Contrast Ratio	3000:1 (DCR)
Response Time	9 ms
Viewing Angle	178 / 178
MTBF	50,000 Hrs
Color Depth	16.7 Million (8bits)
Pixel Pitch	0.510 x 0.510
Lamp Quantity	20 EEFL
Surface Treatment	AG (3H)
VIDEO	
Max Input Resolution	768p
H-Scanning Frequency	30~83kHz (Analog/Digital)
V-Scanning Frequency	56~75Hz (Analog), 60Hz (Digital)
Synchronization Type	Separate/Composite/SOG (Sync On Green)/Digital

INPUTS AND OUTPUTS	
15 Pin D-Sub	RGB In/RGB Out
HDMI (digital) with HDCP	1 In/DVI (through HDMI to DVI adapter-not included)
S-Video	1 In
Component	2 Component In (1080i) BNC with audio
Composite	1 in/1 out (BNC) with audio
PC Audio Input	Yes
RS-232C	RS-232C In / RS-232C Out
Remote Control Input	Yes / IR Jack
External Speaker Out	Yes
CONTROL	
Key Number	8
Key Location	Right Bottom
Key Type	Tact Switch
LED color	Amber-off/Green-on
OSD Language	English, French, German, Italian, Spanish, Portuguese, Korean
POWER	
Power Supply	Internal
Rated Voltage	AC 100 - 240V ~ 50/60Hz 1.5A
Power On Mode	220W
DPM Off	1W (RGB)/4W (HDMI/DVI)
Off Mode	1W
Sleep Mode	< 1W (RGB) / 4W (HDMI/DVI)
ENVIRONMENTAL CONDITIONS	
Operational Condition Temperature	Temperature: 50°F ~ 95°F, 10°C ~ 35°C, Humidity: 10% ~ 80%
Storage Condition	Temperature: -4°F ~ 140°F, -20°C ~ 60°C, Humidity: 5% ~ 95%
CABINET	
Color	Black
Monitor Dimensions (WxHxD)	39.2" x 23.1" x 4.5"
Weight	46.7 lbs
Carton Dimensions (WxHxD)	44.1" x 26" x 11.2"
Packed Weight	55.6 lbs
VESA™ Mounting	Yes (600mm x 400mm)
AUDIO FEATURES	
Max Audio output	20Watt (10W x 2EA)
Audio	Built-in AMP, Equalizer, Auto Volume Limiter, Balance, Speaker on/off
SSM	Surround Max, Flat, Music, Movie, Sports, User
SPECIAL FEATURES	
XD Engine	Yes
XD Demo	Yes (not available in RGB PC/HDMI/DVI PC Mode)
Pb Free	Yes
DDC/CI	Yes
Intelligent Auto (Auto Resolution)	Yes
Temperature Sensor	Yes
Lamp Fault Sensor	Yes
LG Logo Light	Off / On selectable
ISM Method	Normal, Orbiter, Inversion, White Wash
PSM	Dynamic, Standard, Mild, User 1, 2
CSM	Warm, Normal, Cool, User
CERTIFICATIONS	
UL (cUL)	Yes
TUV	Yes
NEMKO	Yes
FCC-B, CE	Yes
CB scheme	Yes
VCCI	Yes
GOST	Yes
MIC	Yes
C-tick	Yes
RoHS compliant	Yes
ACCESSORIES	
Remote Control/AAA Batteries (2)	
User's Guide/Driver CD-Rom/Warranty Card	
15-pin D-Sub Signal Cable	
Power Cable	
Audio Cable (PC)	
RCA-PC Audio Cable	
110/220V AC Universal Power Supply	
USB Cable	
OPTIONAL ACCESSORIES (ORDER THROUGH LG)	
Speakers (SP0000K)	Black
Speaker Dimensions (WxHxD)(each)	2.88" x 13.72" x 2.17"
Weight (each)	0.80 lbs
Packaging Dimensions (WxHxD)	15.12" x 5.28" x 6.85"
Packed Weight	2.36 lbs (2 speakers/1 package)
Stand (ST4210K)	Black/Silver
Stand Dimensions (WxHxD)	24.41" x 6.2" x 11.5"
Weight	7.9 lbs.
Packaging Dimensions (WxHxD)	31.2" x 9.64" x 14.57"
Packed Weight	11.68 lbs.
LIMITED WARRANTY	
	3 years (parts/labor)

TO ORDER M4212T-BA, CONTACT YOUR KRISTEL DISPLAYS REPRESENTATIVE AT 1.630.443.1290 EXT. 103

Kristel Displays 555 South Kirk Road, St. Charles, IL 60174. Contact information: Phone: 630.443.1290 EXT. 103, Fax: 630.443.1390. For more information visit www.kristel.com

TO ORDER OPTIONAL ACCESSORIES, CONTACT YOUR LG REGIONAL SALES MANAGER TOLL-FREE AT 1.800.897.8788

LG Electronics USA, Inc. Commercial Products Division 2000 Millbrook Drive, Lincolnshire, IL 60069. Contact Information: Phone for B2B channel: 1.800.897.8788.

For more information visit www.LGcommercial.com

© Copyright 2009 LG Electronics USA, Inc. All Rights Reserved. LG Life's Good is a registered trademark of LG Corp.

Screen image is simulated. Dimensions and weights are approximate. Design, features and specifications subject to change without notice. VESA is a registered trademark of Video Electronics Association. All other corporate and brand names are trademarks of their respective owners. HDTV monitors require optional set-top box to receive high-definition broadcasts.

