

RTX 45-55

USER AND INSTALLATION
MANUAL

ENGLISH

IMPORTANT SAFETY INSTRUCTIONS

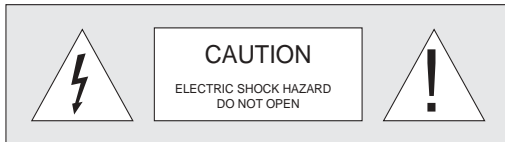

This symbol indicates the possible electric shock hazard associated with uninsulated live components in the interior of the unit.



This symbol indicates the presence of important instructions regarding use and maintenance of the product.

The RTX system consists of two parts connected by a fibre optic cable: the DigiOptical Image Processor and the Display. In this manual references to the "unit" refer to one of the two units that make up the system.

- **Read this manual carefully and keep it in a safe place for future consultation.**

This manual contains important information on how to install and use this equipment correctly. Before using the equipment, read the safety prescriptions and instructions carefully. Keep the manual for future consultation.

- **Do not touch internal parts of the units.**

The units contain electrical parts carrying high voltages and operating at high temperatures. Do not remove the cover from the units, refer to qualified service personnel for all repair and maintenance requirements.

The warranty will be automatically invalidated if the cover is removed from the units.

- **Power supply disconnect device.**

The device for disconnecting the units from the mains power supply is constituted by the power cable plug. Ensure that the power cable plugs and the electrical mains socket outlets are easily accessible during installation operations. To disconnect the units from the electric power supply, pull the plug to remove it from the socket outlet. Do not pull the power cable.

- **Use only the specified type of mains power supply.**

Connect the units to a mains electrical supply with rated voltage of between 100-240 VAC, 50/60 Hz and equipped with a protective earth connection. If you are unsure of the type of mains power supply in your home, consult a qualified electrician.

Ensure that the power draw of the units is commensurate with the rating of the electrical socket outlets and any extension cables that are used.

- **Federal Communication Commission (FCC Statement).**

This equipment has been tested and found to comply with the limits for a Class B digital device, pursuant to Part 15 of the FCC rules.

These limits are designed to provide reasonable protection against harmful interference when the equipment is used in a commercial environment. This equipment generates, uses and can radiate radio frequency energy and, if not installed and used in accordance with the instruction manual, may cause harmful interference to radio communications. However, there is no guarantee that interference will not occur in a particular installation. If this equipment does cause harmful interference to radio or television reception, which can be determined by turning the equipment off and on, the user is encouraged to try to correct the interference by one or more of the following measures:

- Reorient or relocate the receiving antenna
- Increase the separation between the equipment and receiver.
- Connect the equipment into an outlet on a circuit different from that to which the receiver is connected.
- Consult the dealer or an experienced radio/TV technician for help.

For the DigiOptical Image Processor use exclusively the power supply unit provided or an alternative power supply unit expressly approved by SIM2.

- **Beware of power supply cables.**

Position the power supply cables so that they do not constitute an obstruction.

Position the power supply cables where they cannot be reached by children.

Install the units as close as possible to the wall electrical socket outlet. Do not tread on the power cables, make sure that they are not tangled or pulled; do not expose the power cables to heat sources; make sure that the power cables do not become knotted or kinked. If the power cables become damaged, stop using the system and request the assistance of an authorised technician.

- **Disconnect the apparatus from the mains power supply in the event of electrical storms and when not in use.**

To avoid damage that could be caused by lightning striking in the vicinity of your home, disconnect the units in the event of electrical storms or when the system will remain unused for prolonged periods.

- **Avoid contact with liquids and exposure to humidity.**

Do not use the units near water (sinks, tanks, etc.); do not place objects containing liquids on top of or near the units and do not expose them to rain, humidity, dripping water or spray; do not use water or liquid detergents to clean the units.

- **Prevent the units from overheating.**

Do not obstruct ventilation openings. Do not place the units near heat sources such as heaters, radiators or other devices that generate heat (including amplifiers). Do not position the units in confined, poorly ventilated places (bookcase, shelves, etc.).

- **Do not expose the eyes to the intense light emitted by the lamp.**

Never look directly at the lamp through the ventilation opening when the unit is switched on.

Risk of eyesight impairment. Ensure also that children do not look directly at the lamp.

- **Position the unit on a stable surface.**

To avoid serious injury to persons and damage to property, make sure the units are placed on a level, flat and stable surface from which they cannot fall, tip over or slide. Pay special attention if the units are placed on a trolley so that they can be moved around. Ensure that the units are not subjected to impact.

- **Do not insert objects through the units' openings.**

Make sure that no objects are inserted inside the units. If this should occur, disconnect the unit from the power supply immediately and call an authorised technician.

- **For customers in Canada**

This Class B digital apparatus complies with Canadian ICES-003.

- **For customers in the United Kingdom**

ATTENTION: This apparatus must be earthed.

The wires in this mains lead are coloured in accordance with the following code:

Green-and-Yellow: Earth

Blue: Neutral

Brown: Live

As the colours of the wires in the mains lead of this apparatus may not correspond with the coloured markings identifying the terminals in your plug proceed as follows:

The wire which is coloured green-and-yellow must be connected to the terminal in the plug which is marked by the letter E or by the safety earth symbol or coloured green or greenand- yellow.

The wire which is coloured blue must be connected to the terminal which is marked with the letter N or coloured black. The wire which is coloured brown must be connected to the terminal which is marked with the letter L or coloured red.

TABLE OF CONTENTS

INTRODUCTION	4
1 INSTALLATION	6
CONNECTING THE TWO UNITS	6
CONNECTING THE VIDEO SOURCES	7
Video	7
S-Video	7
COMPONENT/RGBS	7
Graphics RGB	9
DVI-D	9
RS232 Control	9
Fibre optic link	9
2 OPERATION	10
SWITCHING ON AND OFF	10
KEYPAD	11
REMOTE CONTROL	11
ON SCREEN MENUS	12
Inputs	12
Main Menu	13
Picture	13
Image	14
Setup	15
Info	15
Quick Menus	15
Messages	15
MAINTENANCE AND TROUBLESHOOTING	16
Maintenance and cleaning	16
Troubleshooting guide	16
3 ADDITIONAL INFORMATION	18
TECHNICAL SPECIFICATIONS	18
DIMENSIONS	20
ON SCREEN MENU LAYOUT	21

INTRODUCTION

Congratulations on your choice of the SIM2 Grand Cinema RTX system!

The RTX system combines the signal processing capabilities of the DigiOptical Image Processor with the high fidelity reproduction of the DLP™ technology Display by linking the two units via a fibre optic cable.

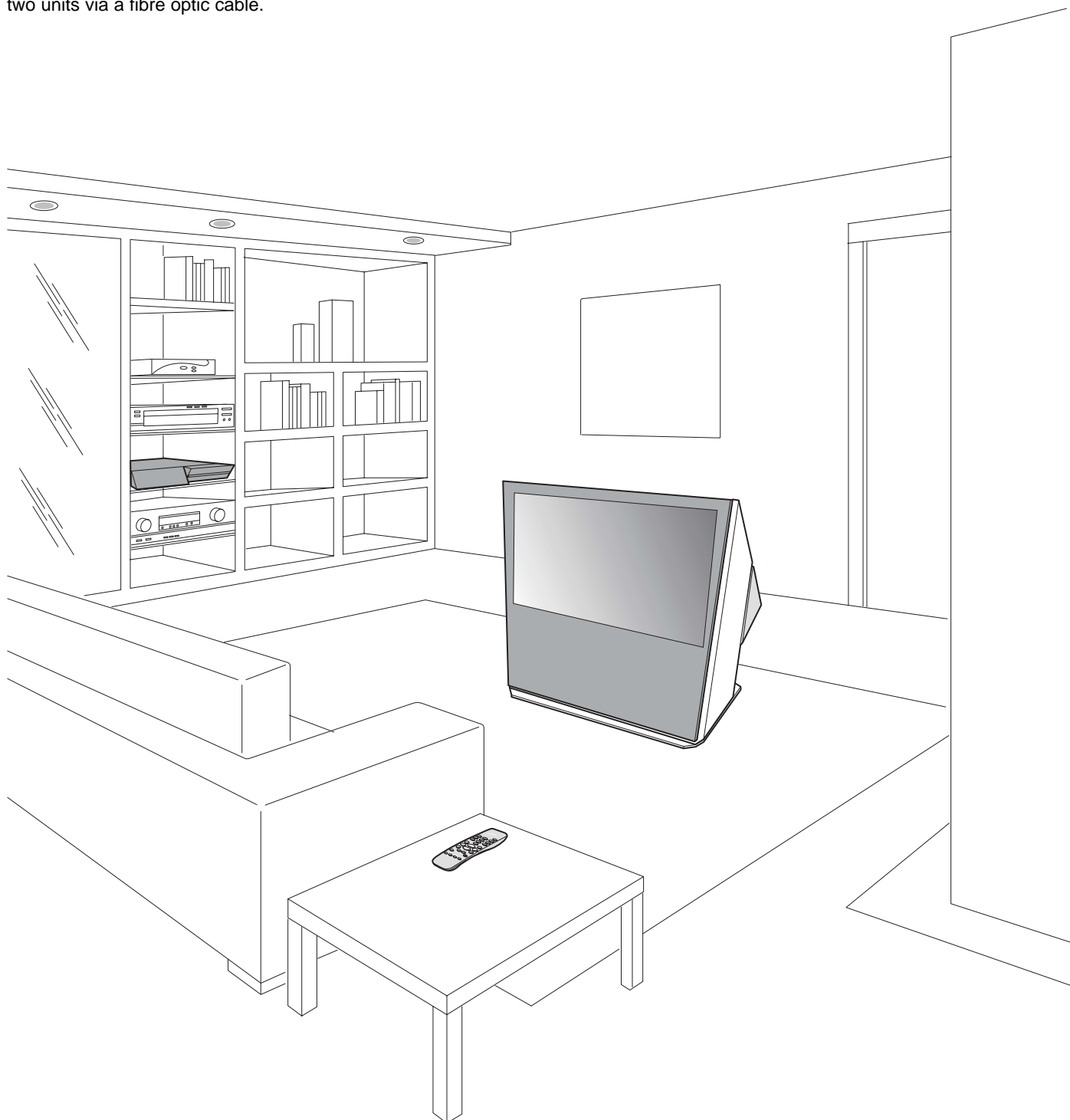

The DigiOptical Image Processor, which should be ideally located close to the signal sources, supports and processes a wide range of video signals, transmitting them to the display by means of a fibre optic link cable.

The large number of inputs available (2 Composite Video inputs, 2 S-Video inputs, up to 4 Component or RGB inputs, 2 graphic RGB inputs and 1 DVI-D input) ensures the system supports a wide variety of analogue and digital sources: DVD players, VCRs, satellite and terrestrial receivers, computers, game consoles, video cameras, etc.

The signal processing capabilities of the Image Processor ensure optimum reproduction of a broad range of input signals, from interlaced video to high definition and graphics.

Conversion of interlaced video signals to progressive signals by means of prestigious DCDi™ technology produces fluid, natural, images free of flicker and stairstepping artefacts.

Faithful reproduction of signals at higher resolutions (such as high definition video and graphics) occurs without loss of information or reduction of image sharpness thanks to the processor's high pixel rate signal acquisition capabilities.

Adaptation of the input signal resolution to the Display resolution occurs without alterations of image quality, in accordance with an ample choice of aspect ratios, including several definable by the user.

All image adjustments can be performed with the remote control with the aid of the On Screen Display; alternatively, the unit can

be controlled by from a home automation system through the serial port.

The Display, with its elegant and original design, produces an image using the very latest Texas Instruments DLP™ technology (1280x720 pixel DMD™ panel with 12° technology), a proprietary dust-sealed optical system, a new six-segment colour wheel and a new type of Fresnel lens. All these features combine to provide a top quality image, with definition, sharpness, colorimetry and contrast on a par with the famous frontal projectors in SIM2's Grand Cinema line.

The two units are connected via a three-core fibre optic cable for transmission of the digital signal from the DigiOptical Image Processor to the Display and control signals in both directions.

Transmission occurs without interference or attenuation over distances of up to 500 m.

Moreover, the flexibility and small size of the cable allow the maximum freedom when installing the system in your home.

1 INSTALLATION

CONNECTING THE TWO UNITS

SIM2's RTX system is made up of the following components (Fig.1):

- Display
- DigiOptical Image Processor
- remote control
- DigiOptical Image Processor power supply unit
- three power cables for the Display
- three power cables for the DigiOptical Image Processor
- triple fibre optic cable for linking the DigiOptical Image Processor and the Display
- four 1.5 V AAA-type batteries for the remote control
- User and installation manual

If any accessories are missing, contact your Dealer as soon as possible.

Connect the power supply unit output cable to the POWER socket located on the rear panel (Fig. 4).

Use exclusively the power supply unit provided with the system or an alternative power supply unit expressly approved by SIM2.

The Display is designed to stand on the floor. Place the Display on a flat, level surface where it has sufficient space for ventilation; to prevent glare and reflections, avoid places exposed to direct sunlight or intense light sources.

The mains power input socket and the power switch are both located on the rear panel.

Adjust the rear feet to obtain the optimum viewing angle in accordance with the distance and height of the viewing position in front of the Display (Fig. 2).

The system can be fully controlled using the supplied IR

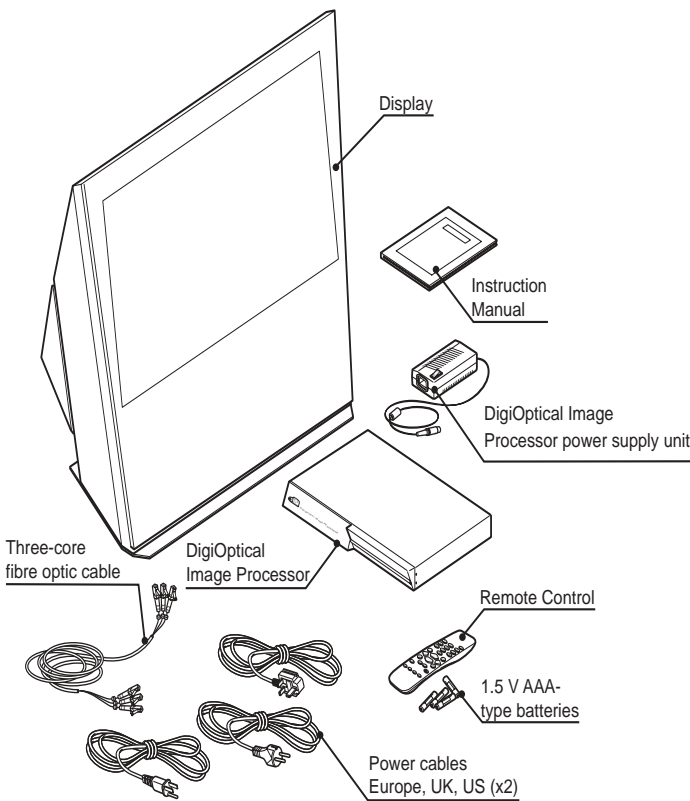

Fig. 1

The RTX system consists of two separate units (the DigiOptical Image Processor and the Display), each of which is equipped with a power cable; the two units are interconnected by a 20 m fibre optic cable.

The ideal location for the DigiOptical Image Processor is on a cabinet shelf or on a rack (dimensions compatible with a standard 19" rack). Make sure that the support surface is stable and that the unit has sufficient space around it for ventilation purposes (at least 3 cm).

The unit is connected to the mains via an external power supply unit with an output of +7 Vdc; the unit's main power switch is on the power supply unit.

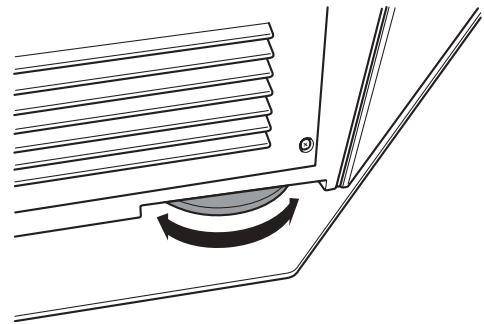

Fig. 2

(infrared) remote control handset. There is a single remote control for both the DigiOptical Image Processor and the Display; the remote control can be directed towards either unit since they are both equipped with an IR sensor.

The connection between the two units is made with a single cable containing three fibre optic cables each terminating in an LC connector. The standard cable length of 20 m will be sufficient for most installation requirements.

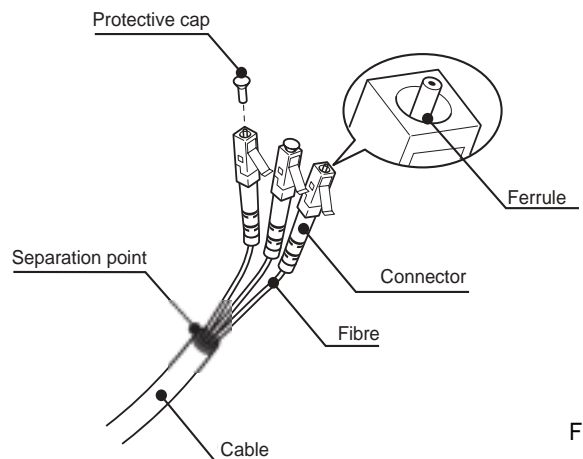

Fig. 3

During installation of the fibre optic cable:

- The individual optical cables are delicate: always handle the main cable without touching the individual optical cables (Fig. 3). Never pull the individual optical cables or connectors; if necessary, you may pull the main three-core cable.
- Only remove the cap protecting the connector ferrule immediately before inserting the connector; if the ferrule is allowed to come into contact with foreign material it may be damaged, making the connector unusable.
- Take particular care when inserting fibre optic connectors in their respective sockets on the rear panel of the DigiOptical Image Processor and the rear panel of the Display (Fig. 5).
- Make sure that the single optical cables are not switched: the numbers on the cables must match the numbers on the connectors.
- Check that the connectors are correctly inserted.
- Use the cable clamps on the rear panel of the Display to protect the connectors from traction and leverage.
- Make sure that the cable does not constitute an obstacle for persons moving around the room.
- Take care not to create knots in the cable; the minimum radius of bends in the cable is 2 cm.
- Prevent the cable from pulling and mechanical stress: this could cause the connectors to be pulled out and damaged.

CONNECTING THE VIDEO SOURCES

Connect the cables from the video sources, the serial cable from the external control unit and the optical fibre cables for connection to the Display, to the rear panel of the DigiOptical Image Processor.

To obtain the best performance from the RTX system, connect the various signal sources using good quality cables designed for video applications (rated impedance 75 Ω).

Ensure that:

- the cables are routed in such a way that they do not present an obstruction to people moving around the room;
- the connectors are inserted carefully to avoid damaging the pins;
- the cables are not twisted or crushed;
- when disconnecting the cables the connectors are not violently pulled out of the sockets on the various units.

Video sources (television receivers, VCRs, DVD players, etc.) often feature several outputs. To obtain the best performance from your system, carefully choose which output to use. Generally, the type of signal offering the best picture quality is DVI-D, followed by RGB, Components, S-Video and Composite Video, in that order.

However, the RTX system is equipped with an excellent Video Decoder and Deinterlacer and therefore even inferior quality signals will produce high quality results.

Table 2 shows the types of signals usually available for the most common types of video sources and the corresponding input connectors to use on the DigiOptical Image Processor.

VIDEO

These inputs should be connected to a Composite Video signal (CVBS) by means of a cable with an RCA connector.

The connector on the source is usually yellow and is frequently labelled VIDEO.

Although other types of signals are preferable (since they allow better picture quality), this is still the most common type of output, and nearly all television receivers, video-recorders, DVD players, video cameras, etc., are equipped with CVBS outputs.

S-VIDEO

These inputs should be connected to an S-Video signal by

means of a cable with a 4-pin mini-DIN type connector.

The corresponding output on the source can be identified by the wording S-VIDEO or Y/C.

Almost as widespread as Composite Video, S-VIDEO is preferable because it offers a clearer and sharper picture.

COMPONENT / RGBS

These inputs are composed of three sets of 5 RCA connectors (5,6,7) and a set of 5 BNC connectors (8).

Each set of connectors is suitable for RGB and Component signals.

RGB signals can have the following synchronisations: composite sync on the green signal (RGsB), H+V Composite Sync, or separate H/V Sync.

Connect the R, G, B outputs of the source to the respective R, G, B inputs of the DigiOptical Image Processor (paying attention not to invert the positions) and any synchronisation signals to the HV input or the H and V inputs. When connecting the three sets of RCA connectors use the colours as a guide: connector R is red, G is green, B is blue, H/HV is white and V is black.

By using a suitable SCART to RCA (or BNC) connector adapter cable, an RGB video signal from a source equipped with an SCART connector can be connected to this input.

Component signals are connected to inputs Y, Cr and Cb, taking care to observe the correspondence with the outputs on the source.

Since the latter can be labelled in various ways, refer to Table 1 to establish the correspondence between the various signals. The connector colours can also be of help, as shown in the table.

Table 1

DigiOptical Image Processor Connector	Video signal source connector		
	Y	Cr	Cb
Y (green)	Y	R-Y	B-Y
Cr (red)	P _R	R-Y	V
Cb (blue)	P _B	B-Y	U

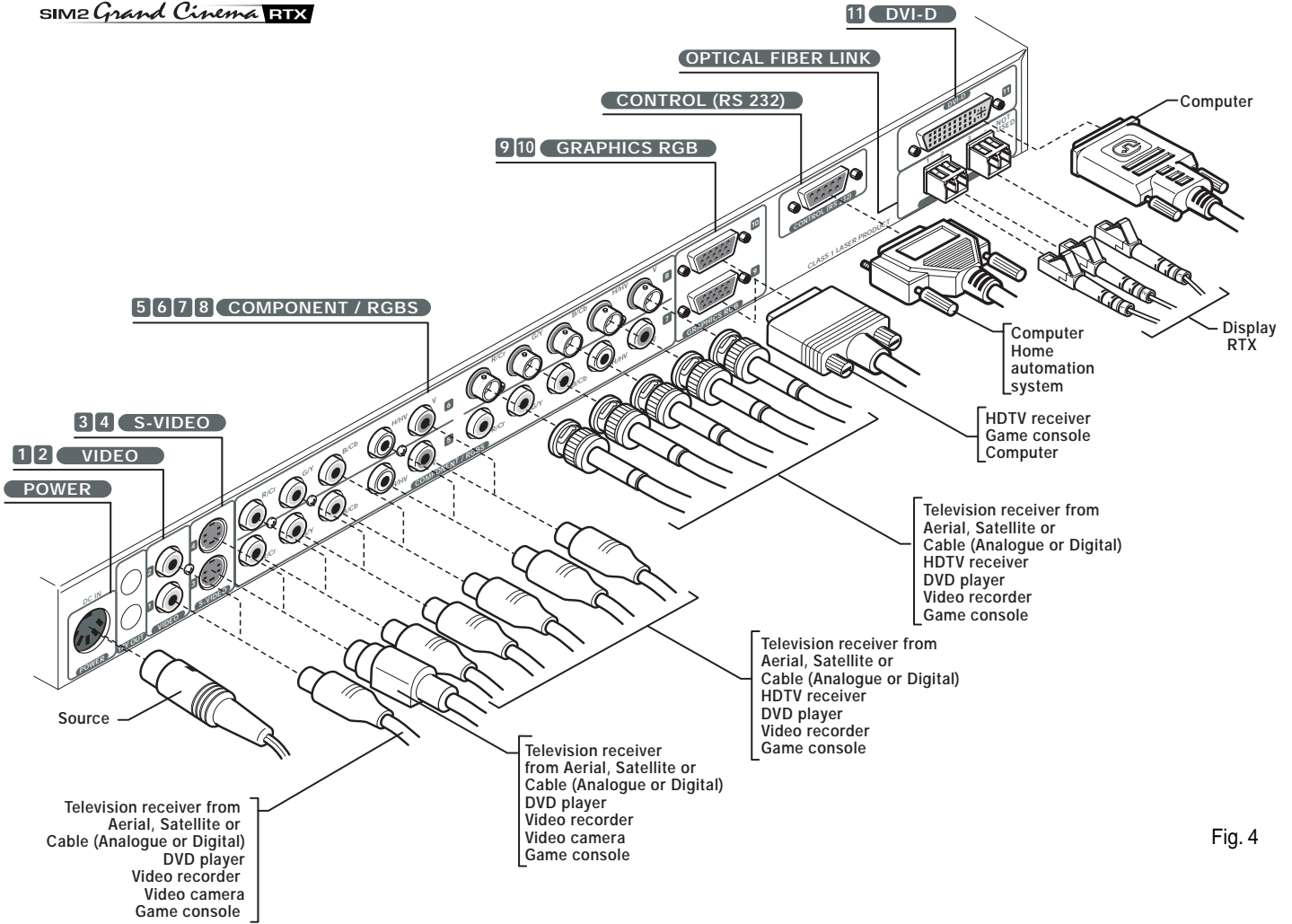

Fig. 4

Table 2

Source	Signal	DigiOptical Image Processor	
		Connector	Input
Television receiver from Antenna, Satellite or Cable (Analogue or Digital)	Composite video	Video	1 2
	S-Video	S-Video	3 4
	Components	Component/RGBS	5 6 7 8
	RGB	Component/RGBS	5 6 7 8
HDTV receiver	Components	Component/RGBS	5 6 7 8
	RGB	Graphics RGB	9 10
DVD player	Composite video	Video	1 2
	S-Video	S-Video	3 4
	Components	Component/RGBS	5 6 7 8
	RGB	Component/RGBS	5 6 7 8
Videorecorder	Composite video	Video	1 2
	S-Video	S-Video	3 4
	Components	Component/RGBS	5 6 7 8
	RGB	Component/RGBS	5 6 7 8
Video camera	Composite video	Video	1 2
	S-Video	S-Video	3 4
Game console	Composite video	Video	1 2
	S-Video	S-Video	3 4
	Components	Component/RGBS	5 6 7 8
	RGB	Component/RGBS	5 6 7 8
	RGB	Graphics RGB	9 10
Computer	RGB	Graphics RGB	9 10
	DVI	DVI-D	11

The video signals that can be connected to this input can have horizontal scanning frequencies of 15 kHz (standard video resolution), 32 kHz, or higher (progressive scanning video, high definition video).

Some sources provide the facility to choose between a progressive signal or an interlaced signal. Although in general a progressive signal is higher quality than an interlaced signal, it is often preferable to perform the deinterlacing operation on the RTX system rather than on the source because the RTX system is equipped with Faroudja's sophisticated directional correlation deinterlacing technology (DCDi™).

Progressive signals usually provide better quality than interlaced signals, but if the source features both progressive and deinterlaced signal outputs it is good practice to compare the quality of the pictures reproduced by the RTX system in the two cases: deinterlacing performed by the RTX system (thanks to Faroudja DCDi™ technology) is often more effective than that performed at the source (typically a DVD player).

RGB GRAPHICS

This input should be connected to an RGB-type video or graphic signal using a cable with a DB15HD type connector.

The signal source device (typically a personal computer or game console) must be able to provide separate H/V synchronisation or composite H+V synchronisation or composite synchronisation on the green signal (RGsB).

The video or graphic signals that can be connected to this input can have horizontal scan frequencies (H-sync) of between 15 and 110 kHz and a vertical frequency (V-sync) of between 40 and 100 Hz. Image resolution can vary between 640x480 and 1600x1200 pixels (VGA, SVGA, XGA, SXGA, UXGA).

DVI-D

If your source is equipped with this type of output (increasingly present on the latest PCs) you can take advantage of the better picture quality by using the DVI-D input.

CONTROL (RS232)

The system can be controlled via a personal computer or home automation systems by means of the serial port: simply connect this input via a serial cable from an RS232 serial port. On request, SIM2 will send you a document containing the serial port settings and the list of main commands.

FIBRE OPTIC LINK

After removing the protective caps from the fibre optic cable connectors and the panel connectors, insert the fibre optic connectors carefully, matching the numbers shown on each element. Be very careful when handling optical fibres cable and connectors.

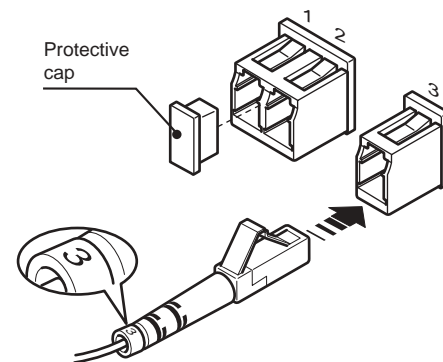

Fig. 5

2 OPERATION

SWITCHING ON AND OFF

The RTX system consists of the Display and the DigiOptical Image Processor (which is also the system control centre). The DigiOptical Image Processor sends commands to the Display and receives operating status information from the Display and function commands from the user. The system can be controlled from either the remote control (via the infrared sensors on the DigiOptical Image Processor and on the Display) or the keypad located on the top of the Display.

The two units have separate power supplies however: after connecting the unit to the electrical mains supply, set the two power switches to "I"; the DigiOptical Image Processor power switch is located on the external power supply unit (Fig. 6a), while the Display switch is on the Display rear panel (Fig. 6b).

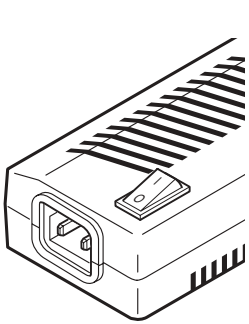

Fig. 6a

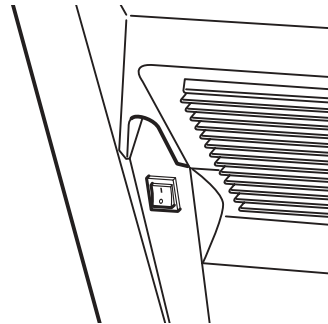

Fig. 6b

After a few seconds (system initialisation interval), the DigiOptical Image Processor and the Display assume stand-by mode. System status information is provided by two LEDs (green and blue) on the front panel of the DigiOptical Image Processor, a blue LED on the front of the Display, and the keypad status (off or illuminated).

Significant status signals are given in Table 3.

If the "No optical link" or "Error" signals are active the system cannot be operated; if the "Warning" signal is active the system

Table 3

Status	DigiOptical Image Processor		Display	
	Green LED	Blue LED	Front LED	Keyboard pad
Off	○	○	○	○
Initialisation	●	●	-	-
Stand-by	○	●	○	●
On	●	○	○	○
Cooling	☀	☀	-	-
Optical link not active	●	☀	●	●
Caution	☀	○	-	-
Error	○	☀	-	-

○ : Off ● : On ☀ : Flashing - : Insignificant

will operate but it may be unable to read certain input signals correctly.

Switching on the system:

- from the remote control (keys 0-9)
- from the Display keypad (keys ↑ and ↓).

Typically, the picture will appear after 15-20 seconds. Pressing a key from 1-9 on the remote control selects the corresponding

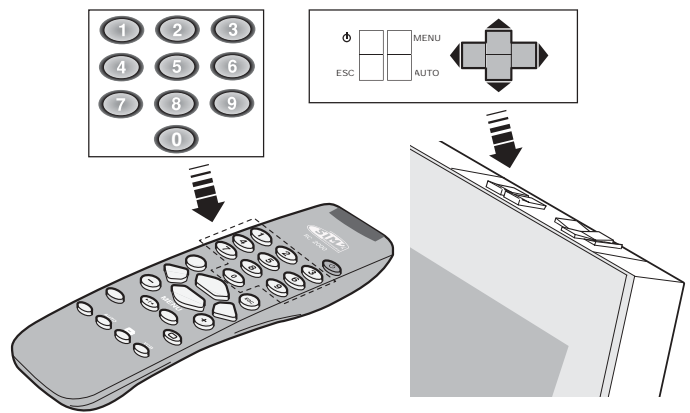

Fig. 7

input; pressing 0 selects the input active at the time the system was last switched off.

If the system is switched on very soon after it was last switched off, the lamp may fail to come on because it is too hot. In this case just wait a few minutes to allow the lamp to cool.

Switching the system off :

- from the remote control (⏻ key)
- from the Display keypad (⏻ key).

If you wish to power off the system completely, wait at least one minute in stand-by before setting the mains power switches on the units to the "O" position or disconnecting the power supply

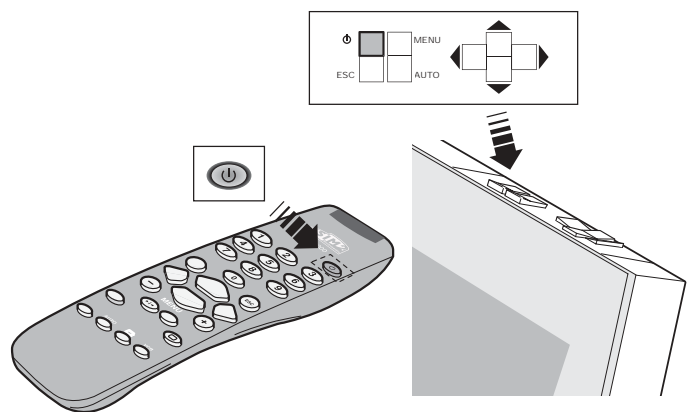

Fig. 8

cables. This is to allow the fans in the Display unit sufficient time to cool the lamp.

KEYPAD

The keypad on the back of the Display features eight keys providing the facility for complete control of the apparatus even without the remote control.

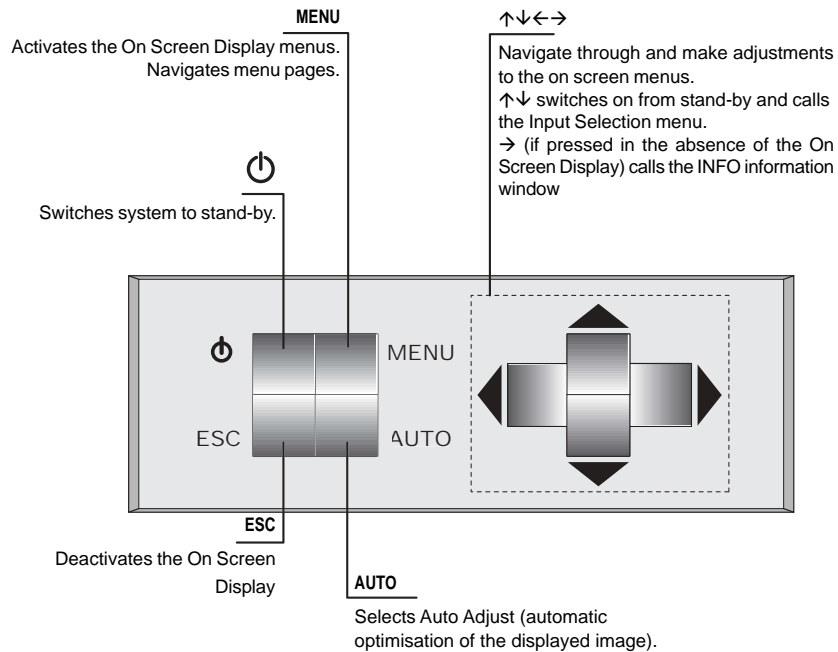

Fig. 9

REMOTE CONTROL

The remote control transmits commands to the system by infrared signals.

There are two infrared sensors, one at the front of the Display and one on the front panel of the DigiOptical Image Processor.

Avoid placing obstructions between the remote control and the infrared sensor at the front of the projector; this will impair the remote control performance.

The remote control requires four 1.5V AAA alkaline batteries. Insert the batteries, taking care to match the polarity, as indicated in the battery compartment in the handset (Fig. 10). Change the remote control batteries if you experience difficulty in transmitting commands to the system.

Remove batteries from the remote control if it is to remain unused for a long period of time to avoid the risk of potentially harmful chemical leaks.

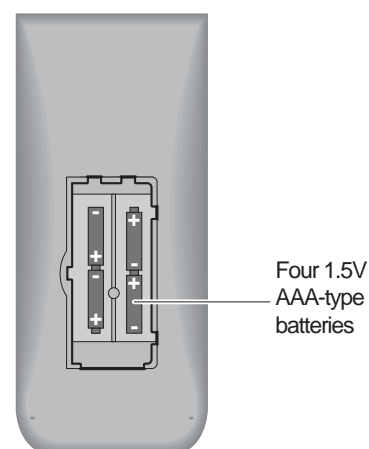

Fig. 10

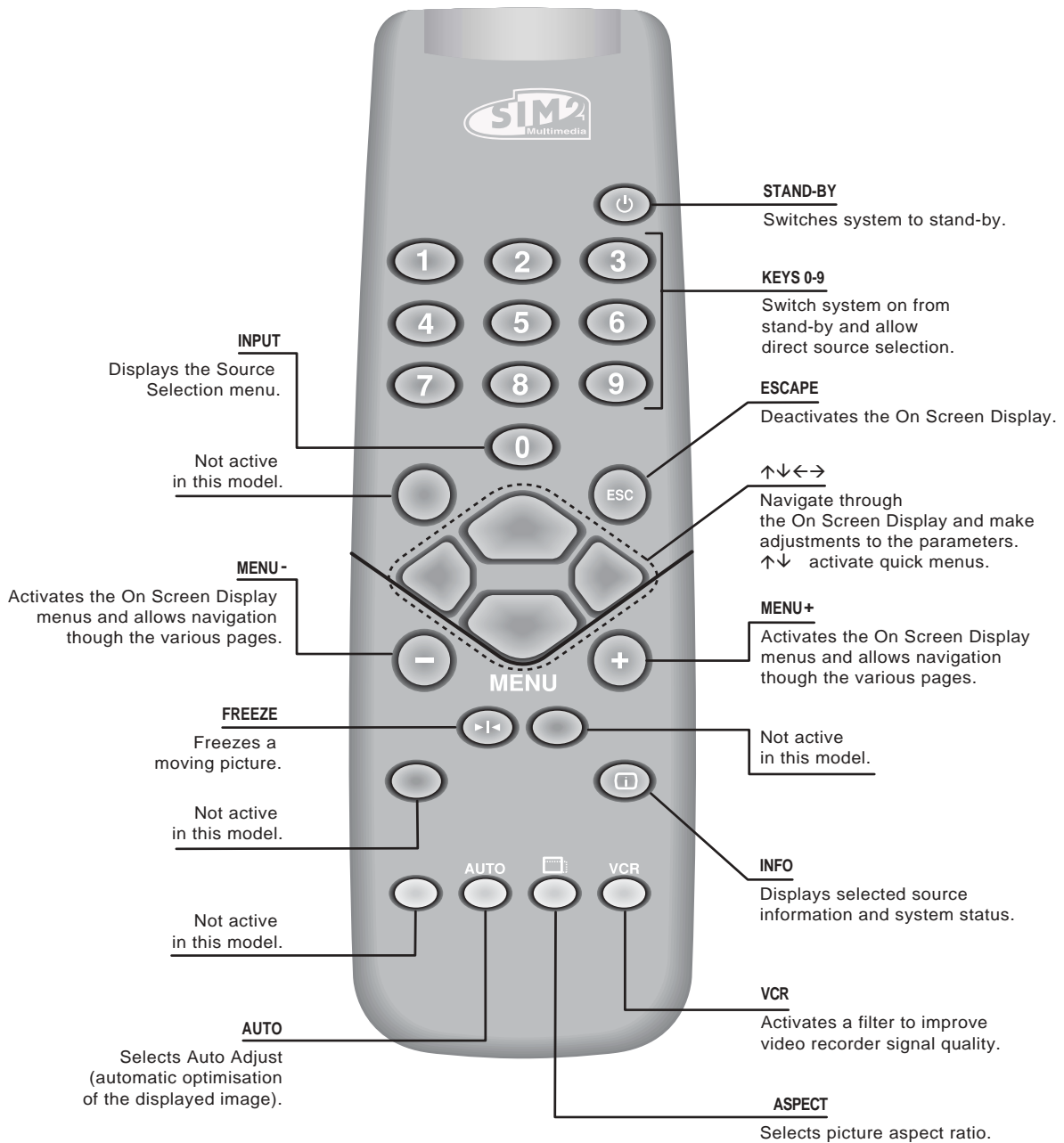

Fig. 11

ON SCREEN MENU

All system functions can be activated from the keypad or remote control with the aid of a practical and comprehensive system of on screen menus.

INPUTS

The input selection menu (Inputs) is called by pressing 0 on the remote control and, when no other menu is displayed, using the \uparrow and \downarrow keys on the keypad. To select an input, scroll the list with the \uparrow and \downarrow keys until the desired input is highlighted, then press \rightarrow .

Alternatively, press the corresponding numerical key (1...11) on the remote control (for numbers 10 and 11 press keys 1 and 0 (10) or 1 and 1 (11) in rapid succession).

Display of the input selection menu is terminated

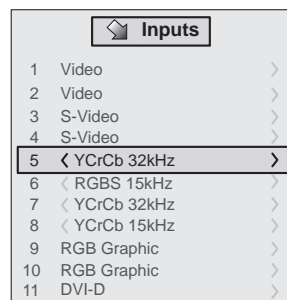

Fig. 12a

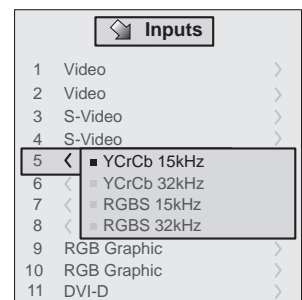

Fig. 12b

by pressing the ESC key, or when the time allowed for displaying the on-screen menu has lapsed (set in the Set-up Menu).

Inputs 5, 6, 7 and 8 can receive RGB and YCrCb signals, at 15 kHz, 32 kHz or higher. The association between the input and the type of signal is made from the pull-down menu that appears on the right of the < symbol after pressing the < key (Fig. 12b). After selecting the source signal (by means of the ↑ and ↓ keys), press MENU+/MENU- to confirm and close the pull-down menu; the value you have just set will be displayed on the right of the < symbol.

As with the other inputs, you can now select the input just set by pressing the > key.

During the short time it takes to find the signal, a box appears showing the signal requested. As soon as the signal is shown in the box additional information is displayed concerning the video standard (for video signals) or resolution (for graphic signals), and format.

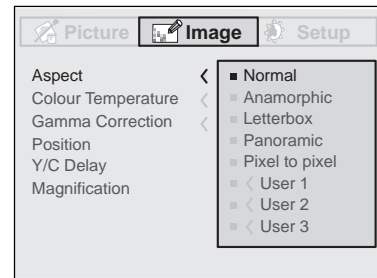

Fig. 14b

These submenus are accessed by pressing the < key, while exit and return to the upper level occurs by pressing MENU+/- . Press ESC on the remote control or keypad to interrupt the menu display or wait for it to disappear automatically after the number of seconds set on the SET-UP page.

MAIN MENU

To access the main menu of the On Screen Display press the MENU key on the keypad or the MENU+ or MENU- key on the remote control.

The main menu is divided into three windows, PICTURE, IMAGE and SETUP, in which the various adjustments are grouped according to the frequency of use. Use ↑ and ↓ to select the line corresponding to the adjustment you wish to make (Fig. 13).

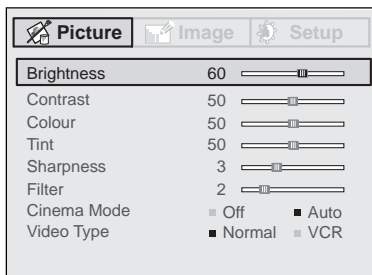

Fig. 13

The various menus only offer the relevant adjustments in accordance with the type of input signal displayed (e.g. certain typical adjustments for video signals, not necessary for graphic signals, do not appear on the menus, and vice versa).

Some adjustments (e.g. BRIGHTNESS and CONTRAST) are associated with a numerical value that can be varied within the set limits using the keys ← / →.

For others (e.g. VIDEO TYPE) you can choose between two options presented on the same line (and selectable using the keys ← / →).

Other adjustments (marked by the < symbol) provide submenus, which appear as a superimposed window in which the selection is made with the ↑ / ↓ keys (Fig. 14).

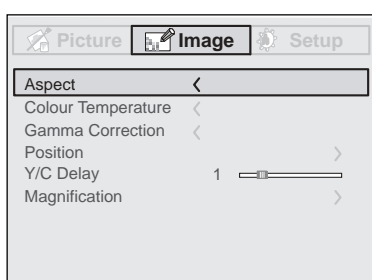

Fig. 14a

PICTURE

This menu features the adjustments related to picture quality. Adjustments that are not available for a given input do not appear on the menu. Table 4 summarises the adjustments available for each input. For a complete overview of the on-screen menus, consult the 'On screen menu layout' in the "Additional Information" section.

BRIGHTNESS

Use this control to adjust the image's black level without affecting white areas. Increasing the value will give more detail in darker parts of the picture. For correct adjustment it may prove useful to display the signal relative to the grey scale within which the black level and the level immediately above it must be separately identifiable. Alternatively use a scene composed of black objects alongside other dark coloured objects.

CONTRAST

Use this control to adjust the image's black level without affecting white areas.

To ensure correct adjustment, it may prove useful to display the signal relative to the grey scale, within which the white level and the level immediately below it must be separately identifiable. Alternatively use a scene composed of well-lit white objects surrounded by light coloured objects with lower level lighting.

COLOR

This control (also called Saturation) increases or decreases the picture colour intensity. When set to zero, colour images will be shown in black and white. Increasing the value, try to find the point at which the colours look natural: suitable references include skin tones and grass in landscape shots.

TINT

Controls the purity of the colours. Basically determines the red-green ratio of the picture.

Reducing the value will boost the red contents of the picture, increasing the value will boost the green tones. For this adjustment use skin tones or a test pattern image with colour bars as a reference.

SHARPNESS

Use this adjustment to increase and decrease the level of picture detail.

When the sharpness value is reduced the image details appear less pronounced, while increasing the value raises image definition, making the outline of objects sharper.

Note that an excessively high value may result in a 'noisy' picture and the edges of objects may be unnaturally defined.

SHARPNESS MODE

This allows you to select the type of processing associated with sharpness adjustment. In the case of a progressive or interlaced video signal VIDEO mode is advisable; with PC graphic signals use GRAPHIC MODE.

FILTER

This allows you to select the mode in which the input signal is processed. Selecting the most appropriate value for a given input signal ensures the best horizontal and vertical definition and makes the picture sharper.

CINEMA MODE

In AUTO the deinterlacer recognises if the video signal source is a movie film (obtained from a Telecine device with 3:2 or 2:2 pull-down) and applies a deinterlace algorithm optimised for this type of signal.

If the video signal source is not identified as a film, or if you select NO the deinterlacer applies a Motion compensated algorithm optimised for video camera signals.

VIDEO TYPE

Activates a filter to improve stability of pictures from video recorders. To toggle between NORMAL and VCR mode, press VCR on the remote control.

IMAGE

This menu features adjustments relating to picture position, aspect ratio, magnification etc.

Table 4

Adjustments	Inputs					
	Video S-Video	RGBS 15kHz YCrCb 15kHz	RGBS 32 kHz	YCrCb 32 kHz	Graphics RGB	DVI-D
Brightness	•	•	•	•	•	•
Contrast	•	•	•	•	•	•
Colour	•	•	-	•	-	-
Tint	o	•	-	•	-	-
Sharpness	•	•	•	•	•	•
Sharpness Mode	-	-	•	•	•	•
Filter	•	•	-	-	-	-
Cinema Mode	•	•	-	-	-	-
Video Type	•	•	-	-	-	-

o Present only if the Video Standard is NTSC

POSITION

Use this adjustment to position the image vertically and horizontally. Determines the aspect ratio of the projected image. These parameters do not normally require adjustment because the system checks the input signal and automatically sets the most suitable values.

However, if the image is not perfectly centralised it may prove useful to request the system to repeat the input signal analysis and image positioning, calling the automatic control procedure from the AUTO button on the remote control or keypad. When this procedure is called it is helpful to have a white or light coloured background on the screen in the current picture.

ASPECT

This adjustment allows you to change the dimensions and aspect ratio (relationship between width and height) of the displayed image. There are five preset aspects available and three

personalised aspects (with user-settable parameters). You can select a different aspect for each source: the selected aspect ratio will be automatically called the next time the relative source is called.

You can also select the required aspect ratio by repeatedly pressing the \square key, or by pressing \square and a numerical key (1...8).

The following aspects are available.

NORMAL

Projects the image occupying the full height of the screen while maintaining the aspect ratio of the input signal. When the input signal aspect ratio is 4:3 black vertical bands are displayed on the right and left of the picture.

ANAMORPHIC

Allows a 16:9 picture to be displayed correctly.

LETTERBOX

Serves to display 4:3 letterbox image (with source signal having black bands above and below the picture) so that it fills the 16:9 screen and maintains the correct aspect ratio.

PANORAMIC

This aspect stretches the 4:3 image, slightly cropping the upper and lower parts.

Panoramic is ideal for displaying a 4:3 image on the 16:9 screen of the Display.

PIXEL TO PIXEL

This aspect displays the image as it is input without adapting it to the screen.

The image is projected in the centre of the screen and if its horizontal and/or vertical dimensions are smaller than the display, it is bounded by vertical and/or horizontal black bands.

USER 1, 2, 3

When none of the preset formulas are suitable, the User formulas are available, with the facility for continuous horizontal and vertical adjustment of picture size.

FREQUENCY/PHASE

These adjustments, available for progressive signals and for signals from PC, ensure correspondence between the number of pixels making up the signal and the number of pixels making up the projected image.

These parameters do not normally require adjustment because the system checks the input signal and automatically sets the most suitable values.

However, if the image appears disturbed (loss of position within the equidistant vertical bands or instability and lack of sharpness on the narrow vertical lines) it may help to prompt the system to repeat the input signal analysis and determination of the best parameters by calling the automatic adjustment procedure with the AUTO key on the remote control or on the keypad.

If the automatic procedure fails to have the required effect, enter the frequency and phase values manually and approach the screen sufficiently to observe the effects of the adjustments.

COLOR TEMPERATURE

Changes the colour balance of the image.

Colours can be adjusted towards the red end of the spectrum (low colour temperature values - expressed in degrees Kelvin) or the blue end (high values).

Colour temperature can be selected with three preset values:

HIGH (corresponding to approx. 9300 degrees Kelvin), MEDIUM (approx. 6500 degrees Kelvin), LOW (approx. 5000 degrees Kelvin) and one PERSONAL setting controlled by the user with separate adjustments for RED, GREEN and BLUE.

Generally, the HIGH value is more suitable for displaying graphic images, MEDIUM and LOW for video images.

These adjustments are reserved for expert users since there is a risk of obtaining results that impair projected image quality.

GAMMA CORRECTION

Determines the system's response to the grey scale, emphasising or attenuating the different grades of brightness (blacks, dark, medium, light grey, whites) in the projected image. The GRAPHICS setting is more suitable for computer images, while the FILM and VIDEO settings are more suitable for video images.

Y / C DELAY

In the case of Video and S-Video signals, it may be necessary to correct horizontal colour misalignment within the projected image. For a given video standard (e.g. PAL or NTSC) the stored value does not normally require further fine-tuning, unless the source or connection cable has changed.

MAGNIFICATION

Allows you to select the area to be viewed and then magnify the projected image.

The degree of enlargement is selected in Zoom mode (identified by a magnifying glass in the centre of the image) using the ← and → keys. The area of the picture to be enlarged is selected in Pan mode (symbol in the centre of the picture) using the ↑ ↓ and ← → arrow keys.

You can toggle between Zoom and Pan mode by pressing the  key on the remote control.

SETUP

The setup menu contains less frequently used adjustments that may be required during installation (e.g. On Screen Display language selection or the display of Test Patterns).

LANGUAGE

Lists the languages available for the On Screen Display menus.

OSD POSITION

Allows the On Screen Display to be positioned in a particular area of the projected image. The OSD can be positioned using the arrow keys for fine adjustments or keys 1...9 on the remote control to select one of 9 preset positions.

Table 5

Adjustments	Inputs					
	Video S-Video	RGBS 15kHz Y/Cb 15kHz	RGBS 32 kHz	Y/Cb 32 kHz	RGB Grafico	DVI-D
Position	•	•	•	•	•	-
Aspect	•	•	•	•	•	•
Frequency	-	-	•	•	•	-
Phase	-	-	•	•	•	-
Colour Temperature	•	•	•	•	•	•
Gamma Correction	•	•	•	•	•	•
Y/C Delay	•	•	-	-	-	-
Magnification	•	•	•	•	•	•

OSD BACKGROUND

Determines the type of background for the On Screen Display.

OSD TIMEOUT

Use this adjustment to set the display time after which the On Screen Display will disappear.

TEST PATTERNS

Displays a series of test patterns that are useful when installing the system and checking basic functions. Use the ↑ and ↓ keys to browse through the test patterns.

FACTORY DEFAULTS

Restores original factory settings except for POSITION and Y/C Delay.

INFO

Displays the current status of the projector and information concerning the projected video/graphic signal.

This function is displayed on pressing  on the remote control (or, in the absence of the On Screen Display, the → key on the remote control).

QUICK MENUS

The quick menus provide access to the main adjustments that affect image quality, without calling the main On Screen menus. BRIGHTNESS, CONTRAST, COLOUR, TINT, SHARPNESS and FILTER adjustments appear at the bottom of the screen one after the other when the ↑ and ↓ keys are pressed ↓.

MESSAGES

The following messages may appear during operation of the system:

No Signal

The system does not recognise any signal applied to the selected input. In this case:

- Make sure the selected input is connected to a video or graphic signal and that that source is functioning correctly.
- Check the condition of the cables used to connect the system to the various sources.
- Make sure the video or graphic signals supplied by the source are compatible with the system's technical specifications and, in particular, with those of the selected input.

Out of Range

This message appears when either the resolution or the vertical/horizontal frequency of the input signal exceeds system specifications (e.g. a QXGA graphic signal) or when an input is supplied with an incompatible signal (after setting the components input to YCrCb 15kHz a progressive signal is connected).

MAINTENANCE AND TROUBLESHOOTING

MAINTENANCE AND CLEANING

The units in the system do not require internal adjustments and do not contain any user-serviceable parts.

For replacement of the lamp or any other service requirements seek qualified technical assistance from your nearest Dealer. A soft cloth is normally sufficient for cleaning the DigiOptical Image Processor or the Display. Use a slightly moistened cloth to remove more stubborn dirt. In this case, before proceeding switch off and disconnect the unit, and ensure that no liquid penetrates to the inside.

TROUBLESHOOTING GUIDE

No power (LEDs always OFF)

- Check that the units' power switches are set to I.
- Check that the power cables are correctly connected to the units' power sockets.
- Check the condition of the fuse located on the power socket on the rear of the Display.
- Replace the fuse located on the display power socket with an identical type (T 3.15A H).
- If the fuse blows repeatedly, seek technical assistance from your nearest Dealer.

Lamp fails to switch on

- Allow a few minutes between switching off and switching on again. This will allow the lamp to cool down sufficiently.
- If the lamp fails to illuminate - even though the unit has had time to cool down - seek technical assistance from your nearest Dealer.
- Check the state of the connection by interpreting the code displayed by the system LEDs in accordance with Table 3.

No picture

- Check that the selected input is effectively connected to an active video or graphic source.
- Make sure the video or graphic signals supplied by the source are compatible with the technical specifications of the RTX system or, in particular, the selected input.
- Check the condition of the cables used to connect the DigiOptical Image Processor to the various sources.
- Check the state of the connection between the DigiOptical Image Processor and the Display.

Picture is disturbed, unstable or noisy

- Check compatibility of the video or graphic signals with the technical specifications of the system, and specifically, with the specifications of the selected input.
- Check the condition of the cables used to connect the DigiOptical Image Processor to the various sources.
- If the problem occurs on a terrestrial broadcast source signal, check that the receiver has been correctly tuned in and that the aerial system is in good working order.
- If the problem occurs in a video signal from a video-recorder, ensure that the videotape is an original "first generation" copy and that VCR mode is active in the PICTURE menu.
- Adjust the Sharpness parameter in the PICTURE menu to optimise the projected image.

Image incomplete along borders (vertical or horizontal)

- Check compatibility of the video or graphic signals with the technical specifications of the system, and specifically, with the specifications of the selected input.
- Recall the automatic image adjustment function by pressing the AUTO key on the remote control or the Display keypad.
- Adjust the horizontal or vertical position of the projected image using the IMAGE ADJUSTMENTS / POSITION menu.
- Adjust the width and height of the image, selecting Aspect in the IMAGE ADJUSTMENTS / ASPECT menu.

Picture too dark, too pale or unnaturally coloured

- Check compatibility of the video or graphic signals with the technical specifications of the system, and specifically, with the specifications of the selected input.
- Adjust the CONTRAST, BRIGHTNESS, COLOUR and TINT parameters in the PICTURE menu.
- If necessary, adjust COLOR TEMPERATURE and GAMMA CORRECTION (IMAGE menu).

Graphic image with poor quality vertical detail

- Check compatibility of the video or graphic signals with the technical specifications of the system, and specifically, with the specifications of the selected input.
- Press AUTO (on the remote or keypad) to execute automatic adjustments.
- Adjust FREQUENCY and PHASE parameters in the IMAGE menu to optimise vertical detail of the projected image.

Video image showing colour misalignment on vertical details

- Check compatibility of the video or graphic signals with the technical specifications of the system, and specifically, with the specifications of the selected input.
- Adjust Y/C DELAY settings in the IMAGE menu to reduce colour misalignment.

Remote control not working

- Check remote control battery power and correct polarity.
- Ensure the area between the infrared sensors (on the front panel of the DigiOptical Image Processor and the front of the Display) and the remote control is free from obstructions.
- Make sure the infrared sensors on the front panel of the DigiOptical Image Processor and at the front of the Display are not exposed to intense light levels.

3 ADDITIONAL INFORMATION

TECHNICAL SPECIFICATIONS

DISPLAY

OPTICAL

Optical system:	optical engine based on 1 DMD™ chip; sealed dust-proof housing
DMD™ panel:	TI HD2 0.8" 12° Dark Metal - 1280x720 pixels (aspect ratio 16:9)
Projection lens:	UltraWide angle F/2.4
Colour wheel:	6 segments (RGBRGB) - 9000 rpm max
Lamp:	120 W UHP - 6,000 hours*
Picture size:	45": 996x560 mm (39.2x22 in) 55": 1218x685 mm (48x27 in)
Brightness:	45": 500 cd/m ² 55": 350 cd/m ²

*average value measured in the laboratory under optimal conditions; can be reduced by improper use

ELECTRICAL

Input/Output:	3-channel fibre optic link
Control:	Panel (keypad), remote control

GENERAL

Power supply cable:	(EU, UK and US); length 2 m
Power supply:	100 to 240 Vac, tolerance +/- 10%, frequency 48 to 62 Hz
Peak current:	30 A max
Consumption:	170 W max
Fuse:	T 3.15A H, 5 x 20 mm
Dimensions:	45": 1228 x 1108 x 373 mm (WxHxD) 55": 1495 x 1218 x 421 mm (WxHxD)
Weight (approx.):	45": 65 kg 55": 85 kg
Operating Temperature:	10 to 35 °C
Transportation temperature:	-15 to 55 °C
Storage temperature:	-15 to 55 °C
Humidity:	20% to 95% non-condensing
Safety:	EN 60950, UL 60950
Transportability:	desktop equipment
Electromagnetic compatibility:	EN 55022 Class B EN 55024 EN 61000-3-2 EN 61000-3-3
Transport:	IEC 68-2-31, IEC 68-2-32

DIGIOPTICAL IMAGE PROCESSOR

ELECTRICAL

Input signals:

- 2 COMPOSITE VIDEO (CVBS)
RCA type connectors, gold-plated
1.0 V_{pp} / 75 Ω, negative synchronisation
- 2 S-VIDEO (Y/C)
4-pin mini-DIN connectors
Y: 1.0 V_{pp} / 75 Ω, negative synchronisation
C: 0.286 V_{pp} / 75 Ω, [NTSC nominal burst level]
0.3 V_{pp} / 75 Ω [PAL, SECAM nominal burst level]
- 4 COMPONENTS (Y/Cr/Cb/H/V) - RGBHV
3 sets of 5 RCA connectors, gold-plated
1 set of 5 BNC type connectors, gold-plated
- Components signal
Y: 1.0 V_{pp} / 75 Ω, negative or 3-level synchronisation [HDTV]
Cr,Cb: 0.7 V_{pp} / 75 Ω
- RGB signal
R,B: 0.7 V_{pp} / 75 Ω
G: 0.7 V_{pp} / 75 Ω, separate H/V Sync or H+V Sync
1.0 V_{pp} / 75 Ω, negative or 3-level synchronisation [HDTV]
H,V: positive or negative TTL, 0.3-5 V_{pp} / 1 kΩ

- 2 RGBHV (analogue RGB)
female DB15HD connectors
R,B: 0.7 V_{pp} / 75 Ω
G: 0.7 V_{pp} / 75 Ω, separate H/V Sync or H+V Sync
1.0 V_{pp} / 75 Ω, negative or 3-level synchronisation [HDTV]
H,V: positive or negative TTL, 0.3-5 V_{pp} / 1 kΩ
- 1 DVI (digital RGB)
DVI-D female connector

Input/Output:	3-channel fibre optic link
Control:	Panel (keypad), remote control, via RS232 from PC or home automation devices
Horizontal frequency:	from 15 to 110 kHz (up to UXGA, 85 Hz)
Vertical frequency:	48 -100 Hz
Video standards:	automatically selected (PAL B, G, H, I, M, N, 60, SECAM, NTSC 3.58 and 4.43)
High definition video:	ATSC HDTV (480p, 720p, 1080i, 1080p)
Graphic standards:	VGA, SVGA, XGA, SXGA, UXGA
Deinterlacer:	Faroudja chipset, DCDi™, 3:2 pull down sequence conversion

Colour temperature:	from 5000 to 9300 °K (three presets and one user settable)	Dimensions:	483 x 55 x 200 mm (WxHxD); compatible with 19" rack
Control:	infrared remote control, RS232 serial (DB9 connector, female)	Weight (approx.):	2.5 kg
Outputs:	2 12-V jack connector outputs (1 active with system powered on, 1 active with 16:9 aspect ratio selected)	Operating Temperature:	10 to 35 °C
		Transportation temperature:	-15 to 55 °C
		Storage temperature:	-15 to 55 °C
		Humidity:	20% to 95% non-condensing
		Safety:	EN 60950, UL 60950
		Transportability:	desktop equipment
		Electromagnetic compatibility:	EN 55022 Class B EN 55024 EN 61000-3-2 EN 61000-3-3
		Transport:	IEC 68-2-31, IEC 68-2-32

GENERAL

Power supply cable:	(EU, UK and US); length 2 m
Power supply:	100 to 240 VAC, tolerance $\pm 10\%$, frequency from 48 to 62 Hz
Peak current:	30 A max
Consumption:	30W max

LINK CABLE

Composition:	three 50/125 μm multimode optical fibre cables	Diameter:	5 mm max
Connectors:	LC type	Tensile strength:	1200N*
Length:	20.0 \pm 0.2m	Type Approval:	UL OFNP

*traction applied on outer cable, not on fibre cores or connectors.

DIMENSIONS

DISPLAY

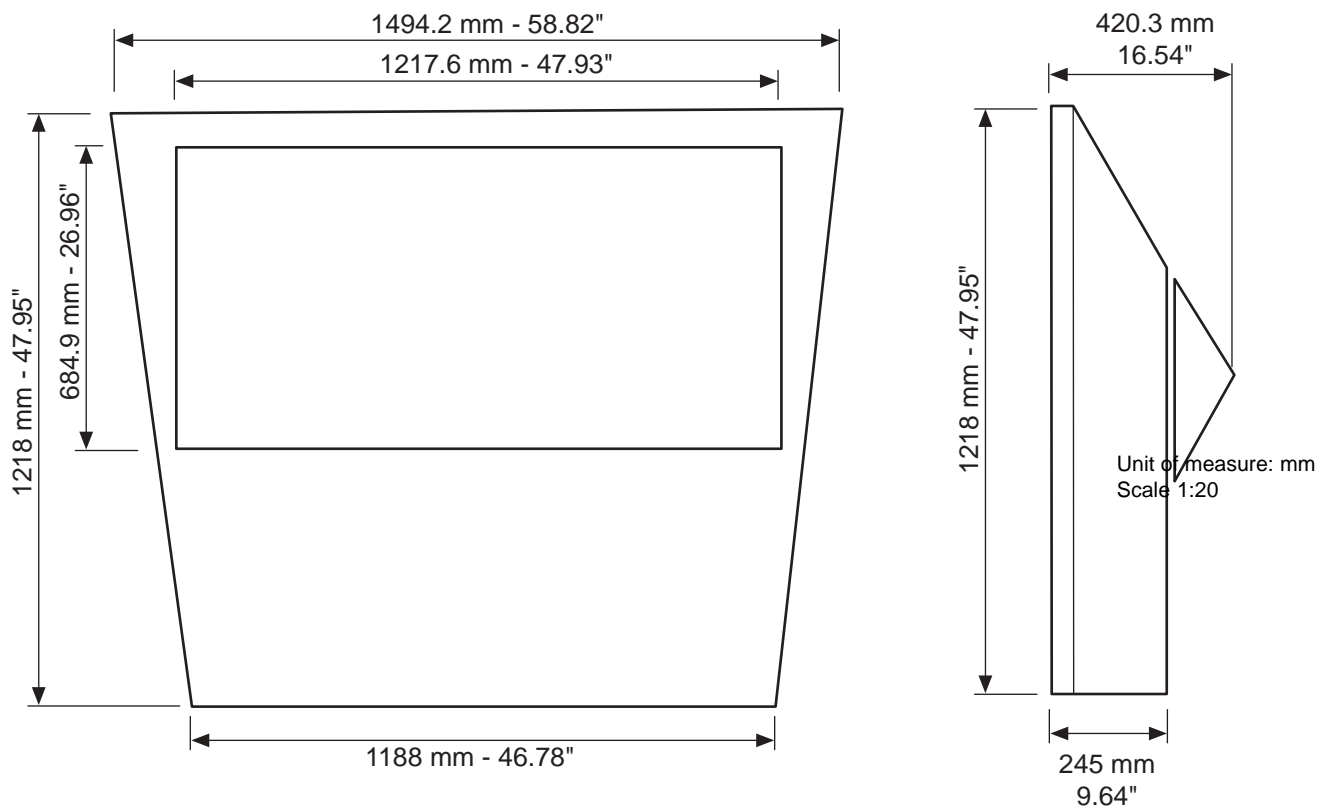
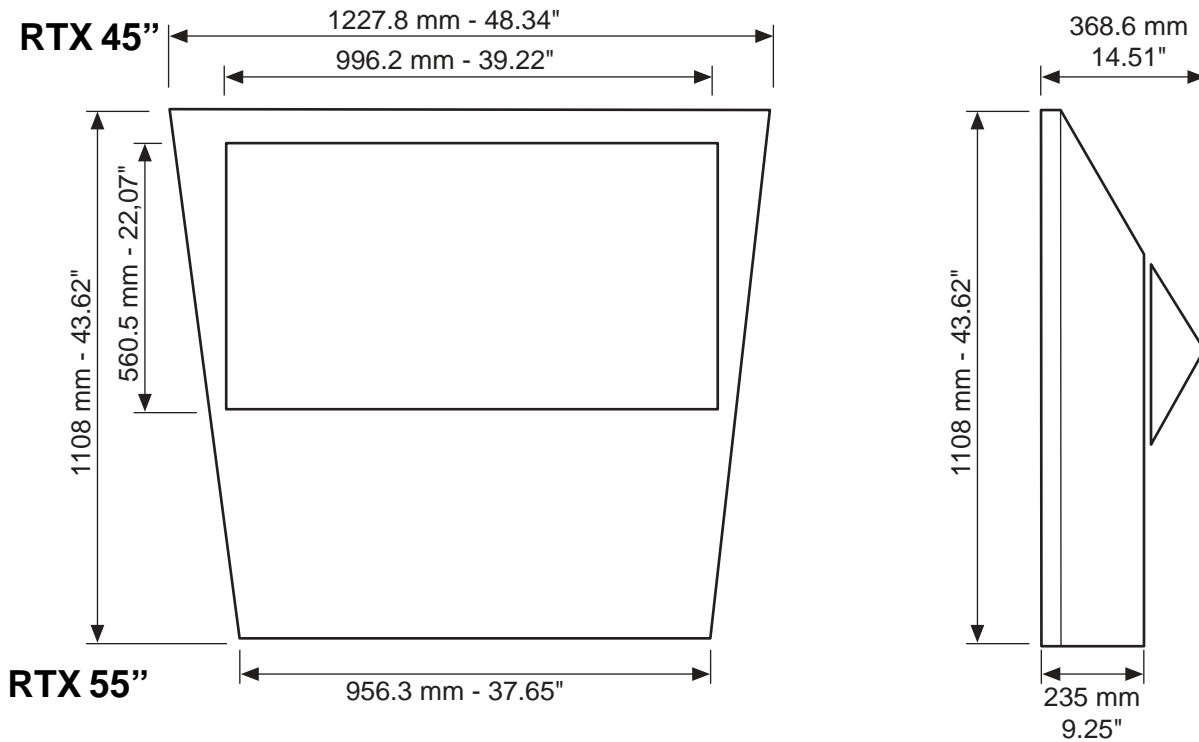

DIGIOPTICAL IMAGE PROCESSOR

Unit of measure: mm
Scale 1:5

ON SCREEN MENU LAYOUT

Picture

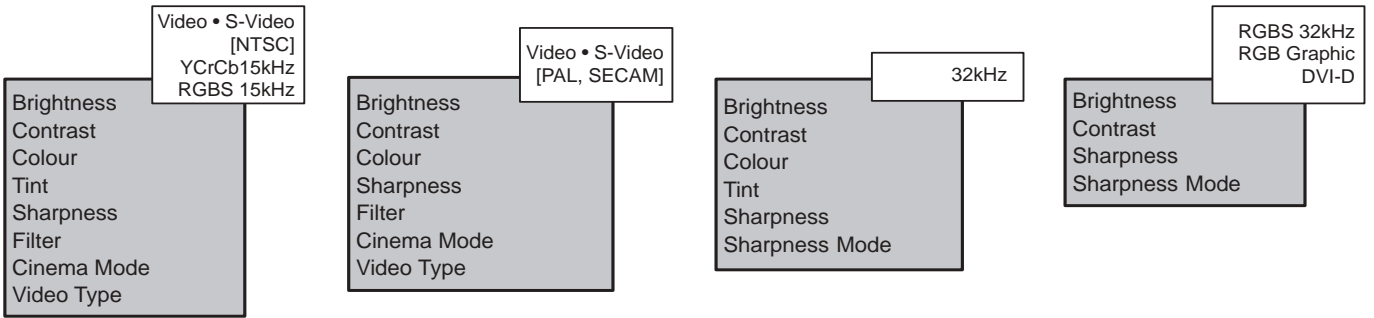

Image

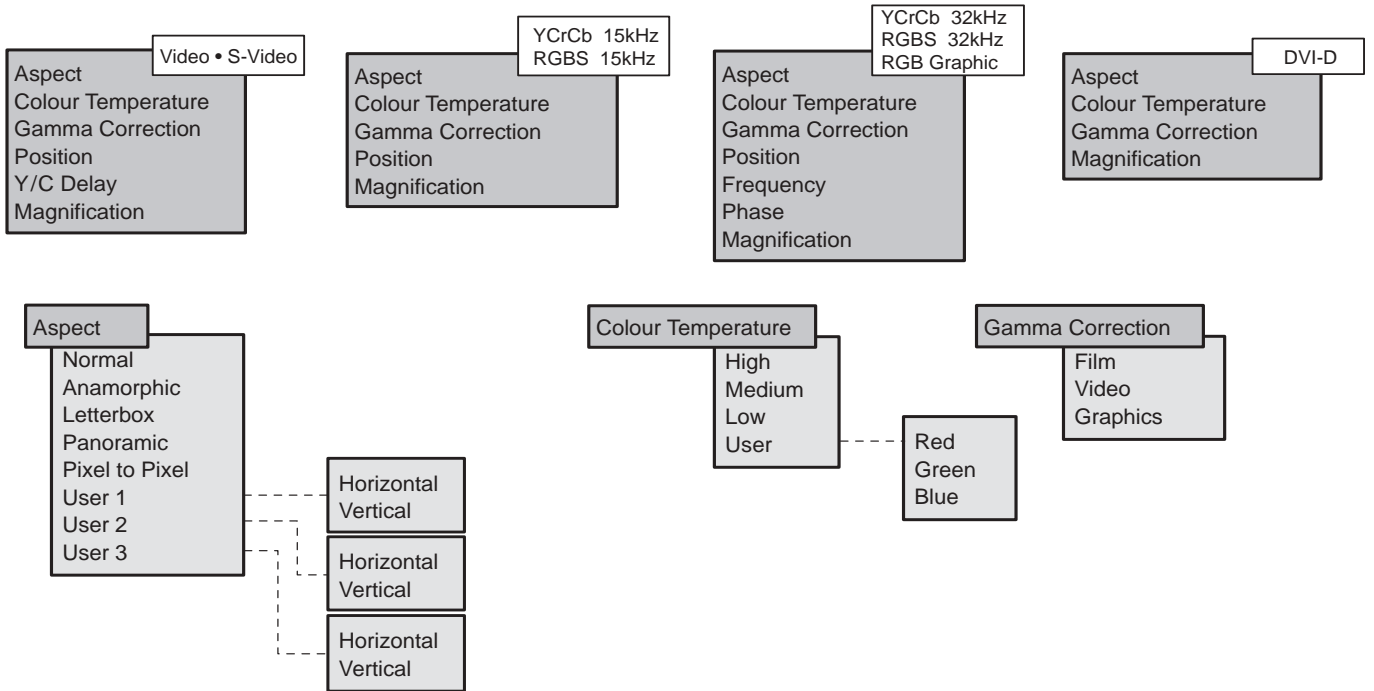

Setup

